

## **Scope**

This cookbook is a tested collection of real applications and reference example circuits. The detailed descriptions of the procedures for selecting the appropriate components will help get your design up and running fast.

Please also consult the data-sheets and evaluation board / development kit descriptions for detailed technical information. These can be found on the Melexis WEB site at [www.melexis.com](http://www.melexis.com). Assistance and questions can be accessed using Melexis Knowledge Base WEB Forum at [www.melexis.com/KnowledgeBase.aspx](http://www.melexis.com/KnowledgeBase.aspx).

## **Applications**

- Portable data terminals,
- Access control readers,
- Contact-less payment terminals,
- Smart label printers.

## **Related Melexis Products**

MLX90121.

## **Main Features**

- Conforms with ISO/IEC 14443A<sup>1</sup>, 14443B (RATP / Innovatron Technology) & 15693
- Programmable encoder and decoder for custom protocols
- Low external component count

<sup>1</sup> Purchase of MLX90121s doesn't imply any grant of any ISO14443A license. Customers are advised to sign patent licensing agreements with all third parties, especially those companies listed in the introduction of the corresponding standard.

**Document Content**

<b>A.</b>	<b>A low power reader based on the MLX90121: Scope .....</b>	<b>4</b>
<b>1.</b>	<b>Application schematic .....</b>	<b>4</b>
1.1.	Recommended Components: .....	4
1.2.	Theory of operation and design guidelines: .....	5
<b>2.</b>	<b>Measured values for a typical application .....</b>	<b>6</b>
<b>B.</b>	<b>A power booster for the MLX90121: Scope .....</b>	<b>7</b>
<b>1.</b>	<b>Power boost with external MOSFET .....</b>	<b>7</b>
1.1.	Application schematic .....	7
1.2.	Recommended Components .....	8
1.3.	Theory of operation and design guidelines .....	8
1.4.	Waveforms at selected test points .....	9
1.5.	Performance summary .....	12
<b>2.</b>	<b>Receiver part .....</b>	<b>13</b>
2.1.	Solution 1: Attenuation of the RX input .....	13
2.2.	Recommended components .....	13
2.3.	Solution 2: External detector .....	14
2.4.	Recommended Components: .....	14
<b>3.</b>	<b>Remarks about PCB layout. ....</b>	<b>15</b>
<b>C.</b>	<b>A 1 Watt 5 volts power booster for the MLX90121: Scope .....</b>	<b>16</b>
<b>1.</b>	<b>Application schematic .....</b>	<b>16</b>
1.1.	Recommended Components: .....	17
<b>2.</b>	<b>Theory of operation and design guidelines.....</b>	<b>17</b>
2.1.	Theory of operation .....	17
2.2.	Fine tuning of the circuit .....	18
2.3.	Printed circuit board layout issues.....	19
<b>D.</b>	<b>MLX90121: Support of different modulation modes: Scope .....</b>	<b>20</b>
<b>1.</b>	<b>Base band communication:.....</b>	<b>20</b>
1.1.	Low data rates: .....	20
1.2.	Medium Data Rates .....	23
1.3.	High Data Rates: .....	24
1.4.	Very High Data Rates.....	25
<b>2.</b>	<b>Applications with a sub-carrier of 212 KHz: .....</b>	<b>26</b>
2.1.	Configuration: .....	26
2.2.	Screen captures: .....	27
<b>3.</b>	<b>Conclusion.....</b>	<b>28</b>
<b>E.</b>	<b>Progressive field increase for the MLX90121: Scope .....</b>	<b>29</b>
<b>1.</b>	<b>Standard design (200 mW @ 5 Volts) .....</b>	<b>29</b>
1.1.	Application schematic .....	29
1.2.	Recommended Components: .....	30
1.3.	Theory of operation and design guidelines: .....	30
1.4.	Oscilloscope screen captures .....	31
<b>2.</b>	<b>Power booster configuration ( 1 Watt @ 12 Volts ).....</b>	<b>34</b>
2.1.	Application schematic .....	34
2.2.	Recommended Components .....	34

<b>F.</b>	<b>A modulation index switch for the MLX90121: Scope .....</b>	<b>35</b>
<b>1.</b>	<b>Standard design (200 mW @ 5 Volts) .....</b>	<b>35</b>
1.1.	Application schematic .....	35
1.2.	Recommended Components: .....	35
1.3.	Theory of operation and design guidelines .....	36
1.4.	Waveforms at the antenna connector.....	36
<b>2.</b>	<b>Power booster configuration (1 Watt @ 12 Volts).....</b>	<b>37</b>
2.1.	Application schematic .....	37
2.2.	Recommended Components: .....	37
2.3.	Waveforms at the antenna connector.....	38

PRELIMINARY

## A. A low power reader based on the MLX90121: Scope

This application note is a design guide to provide a means of reducing the power drain for an RFID reader based on the MLX90121. In some applications, such as hand held readers, the maximum reading range may not be of paramount importance while the operating life of the battery is much more critical.

### 1. Application schematic

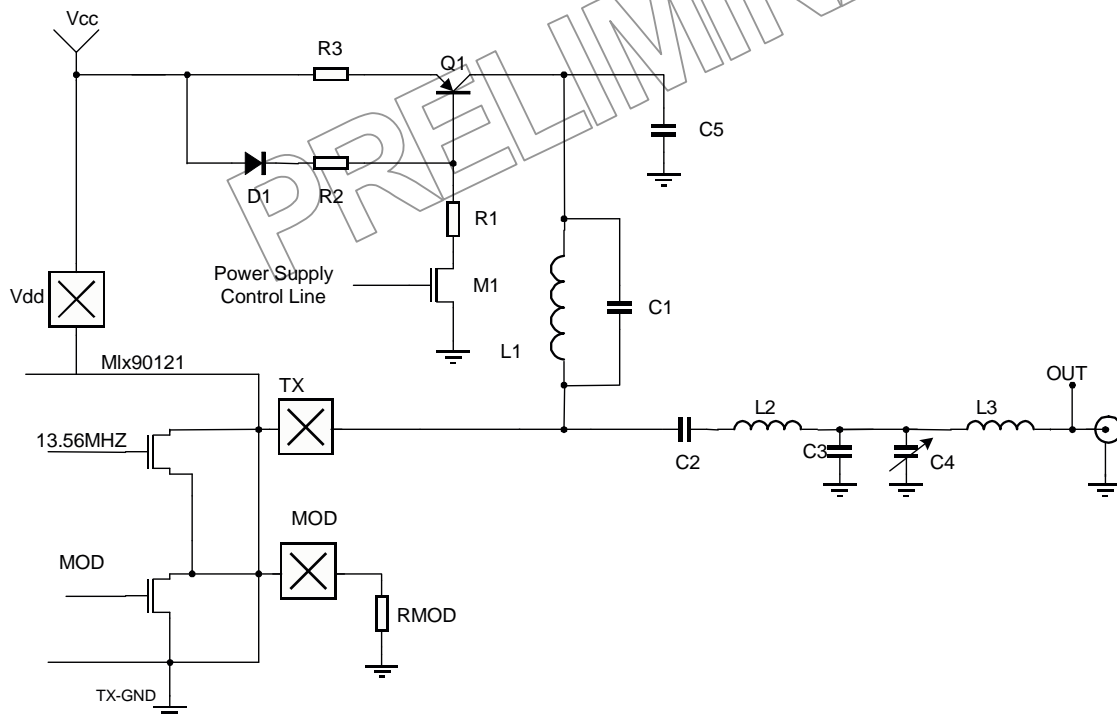

#### 1.1. Recommended Components:

Reference	Value	Comments
R1	See text	5% or better
R2	See text	5% or better
R3	See text	1% or better
M1	FDV301N	FAIRCHILD
Q1	FZT 949	ZETEX
D1	1N4148 or equivalent	
C5	4.7 $\mu$ F	See notes

Note:

Other components values do not differ from the standard recommended reader schematic. C5 should have a very low ESR. Recommended type is AVX TPSD475K050R0300.

**1.2. Theory of operation and design guidelines:**

When transistor M1 is switched on, Q1 is switched on as a consequence and the output transistor of the MLX90121 is energized as well. D1, R2, R3, R1 constitute a current limiter. One can approximate the current limit of Q1 with the following formula:

$$I_{C_{Q1}} \approx \frac{(V_{cc} - VF_{D1}) \cdot R_2}{R_3 \cdot (R_1 + R_2)}$$

Where  $VF_{D1}$  is the forward voltage drop of the diode D1.

In this approximation, the base current of Q1 is neglected. Therefore, it will be more accurate if one selects relatively small values for R1 and R2. But, in doing so, the overall current drain will increase, and one will have to make proper trade-off. Another issue is that the actual voltage drop of D1 should be measured for the current supposed to flow through it. The standard value of 0.7 Volts @27°C may not be correct in this application.

To set a given value for  $I_{C_{Q1}}$ , one can use the following formula, after the values of R3 and R2 have been selected:

$$R_1 = \frac{(V_{cc} - VF_{D1}) \cdot R_2 - I_{C_{Q1}} \cdot R_3 \cdot R_2}{I_{C_{Q1}} \cdot R_3}$$

The current limitation of Q1 will limit the DC current that the MLX90121 can take. This will have as effect that the voltage on C5 will drop to a value such that the MLX90121 output stage will not take more average DC current than Q1 supplies.

In case one would like to use different power settings that are microcontroller settable, one may use the schematic as depicted in figure 2. Using the control lines Control1 and Control2 the two MOS transistors M1 and M2 will switch on either resistor R1 or R4 or the combination of both. These combinations allow for three different power level settings.

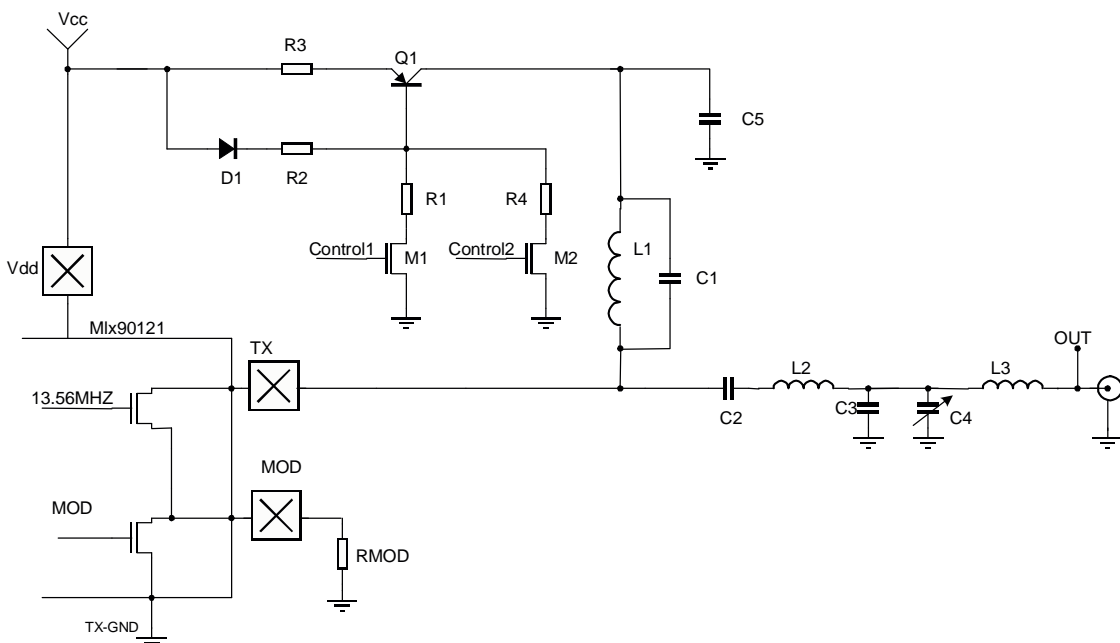

## 2. Measured values for a typical application

The following configuration was used to make these measurements:

- Vcc = 3 Volts
- R2 = 330 ohms
- R3 = 10 ohms
- Antenna: standard Melexis antenna 12 cm x 12 cm.
- Tag and protocol: ISO 15693 FSK / double sub-carrier.

R1 was implemented as a 10 K ohms 25 turns potentiometer.

IC <sub>Q1</sub> mA	Power stage DC voltage Vc5 Volts	Power stage Consumption mW	Antenna power mW	Power Efficiency %	Measured value for R1	Reading distance cm
45	2.44	135	60	44	Below 350 ohms.	17
40	2.4	120	53	44	3.4 K ohms	16
30	1.66	90	30	30	5 K ohms	14.5
20	1.2	60	16	27	6.7 K ohms	13

Notes:

- The reading distance was measured with a ISO15693 FSK / double sub-carrier tag and is given for reference only.
- The antenna power was measured by substituting a 50 ohms load to the antenna. The capacitance of a standard oscilloscope probe would otherwise change the tuning of the reader matching network and hence destroy the measurement accuracy.

As one can see on the previous table, the voltage at C5 drops from 3V to 2.44V when the current is limited to 45mA and to as low as 1.2V when the current is limited to 20mA. The antenna power drops from 60mW to 16mW, and because of the larger voltage drop in Q1 the efficiency of the whole circuit drops from 44% to 27%. Reducing the antenna power from 60mW to 16mW does not decrease a lot the reading distance. In principle the reading distance is reduced to half for an eight-fold decrease in power.

## B. A power booster for the MLX90121: Scope

This application note is a design guide to increase the output power of the MLX90121.

Power boosting is introduced to improve the reading range of tags. The reading range of a tag can in general be limited by two factors:

A first factor is the strength of the transmitted field. A tag needs a minimum field in order to operate. The required field could be quite high for microprocessor cards.

A second limitation is the sensitivity of the reader. When the tag is powered it is normally able to modulate. However the coupling to the reader can be low (this is the case for sensitive tags). Hence the reader might be unable to recover the return signal of the tag.

In both cases reading distance can be gained by increasing the readers' output power. In case one this is straightforward. In case two, where the reading distance is limited by the read sensitivity, the reading distance increases because of a larger return signal coming from the tag as a result of an increased carrier.

In the document below, design issues about power boosting of the MLX90121 will be discussed into some detail and different implementations will be considered. There are two parts in this document: a first part describing the boost output stage that delivers the necessary output power. A second part explains how to make the adaptation of the receiver part to cope with the increased antenna signals.

### 1. Power boost with external MOSFET

#### 1.1. Application schematic

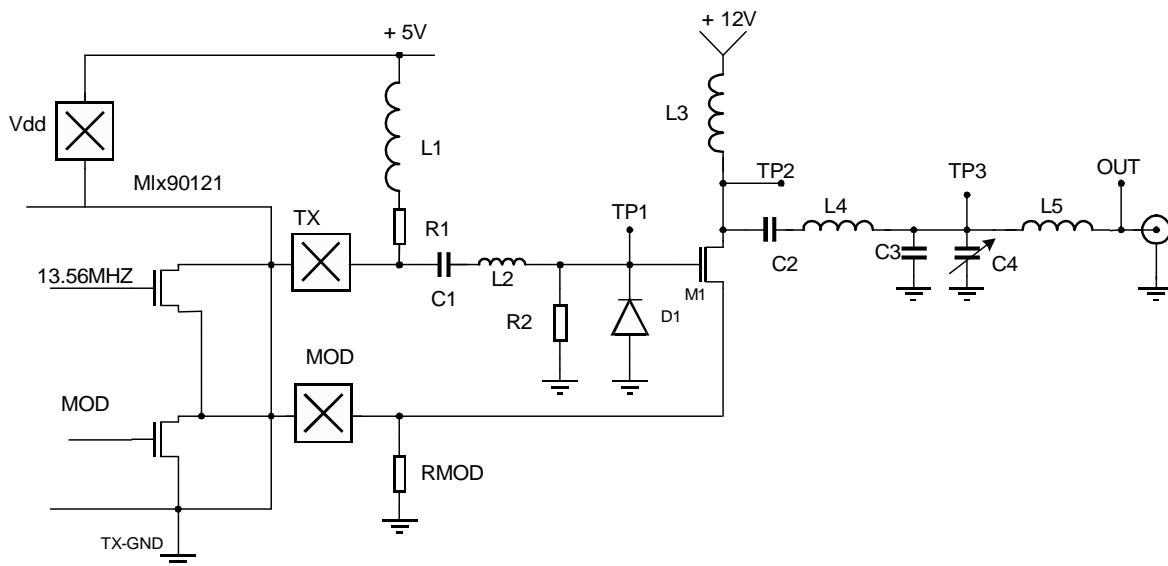

### 1.2. Recommended Components

Reference	Value	Comments
R1	10 ohms	5% or better
R2	680 ohms	5% or better
C1	330pF	50Volts NPO
C2	10nF or 100nF	50 Volts X7R
C3	68pF	100Volts NPO
C4	5-50 variable pF	100Volts
L1	680nH	See note 1
L2	270nH	See note 1
L3	560nH	See note 1
L4	3.3 $\mu$ H	See note 1
L5	2.2 $\mu$ H	See note 1
M1	IRFD110	See note 2
D1	1N4148	See note 3
RMOD	See text	3 to 6 ohms

Notes:

Inductors should be carefully selected. Standard through hole types available from Farnell or Radiospares work well for this application.

IRFD 110, IRFU110, IRFR110 can be interchanged. Manufacturer is International Rectifier.

Any fast silicon diode will work. A peak current of about 300mA will circulate through the diode. It may be replaced by a Schottky.

### 1.3. Theory of operation and design guidelines

L2 forms a series resonant network with M1 gate capacitance. However, it is not possible to drive directly such a network with the MLX90121 output stage because it will draw too much current. Therefore, we mistune it with C1, sufficiently to keep the current requirements in line with the MLX90121 internal power transistor safety area while maintaining enough voltage swing at TP1 to drive correctly the gate of the external power transistor, M1. L1 and R1 provide the necessary DC bias to the MLX90121 internal power transistor. R1 is again selected to maintain the current drain within acceptable limits. R2 provides a DC return path and dampens the resonance. It has a critical role, along with R1, in avoiding spurious oscillations.

L3 provides the DC bias for the power transistor. L4, C3, C4, L5 form an impedance matching network that converts the 50 ohms load into about 150 ohms seen from the drain of M1. Since M1 operates as a pulse generator, this impedance transformation is only theoretical. However, this ratio gives the best results. In this application note, the component values for this network have been selected to provide a Q of about 4. This reduces the peak to peak voltage at TP3 and permits the use of standard components. In order to comply with EMC radiation limits, it might prove necessary to increase the network Q, and in that case, higher voltage ratings for C3 and C4 will be required. For instance, with a Q of 7, the peak to peak voltage will easily reach 200 Volts at TP3. If you need to use a different impedance transformation network, you can use this link to compute component values: <http://rfengineer.cc/match1.htm> .

RMOD should be selected to provide an adequate modulation depth in the low modulation index mode. Its value will be dependent on the external power transistor supply voltage. With a 12 volts supply voltage, a value of 6 ohms gives good results. At 15 volts, the modulation depth increases a lot, so a lower value should be used for RMOD.

**1.4. Waveforms at selected test points**

All waveforms are recorded with the transmitter loaded with a pure resistive 50Ohms load.

**1.4.1. Waveform at TP1**

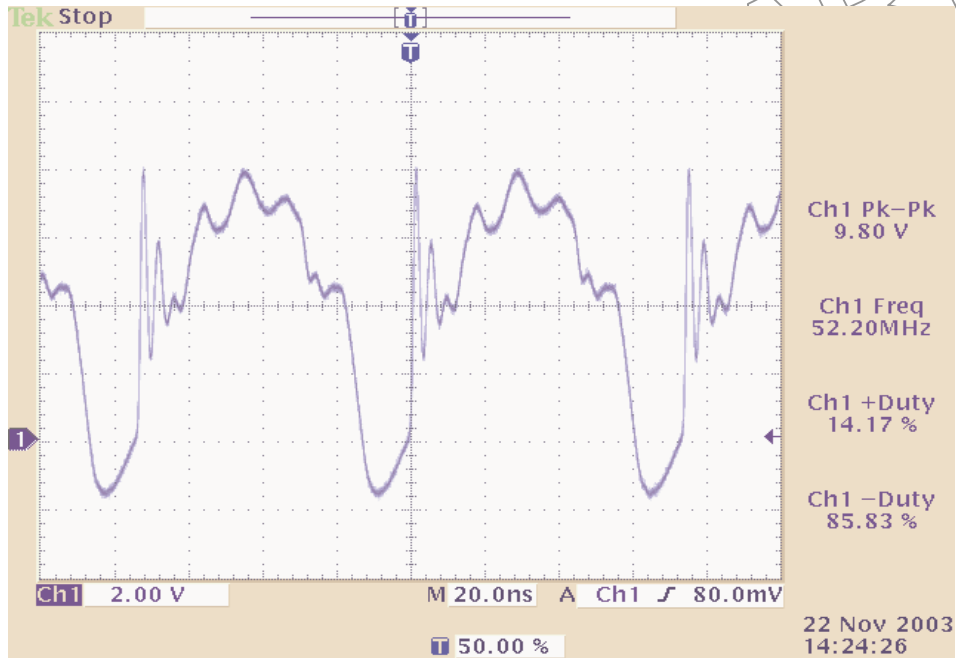

**1.4.2. Waveform at TP2**

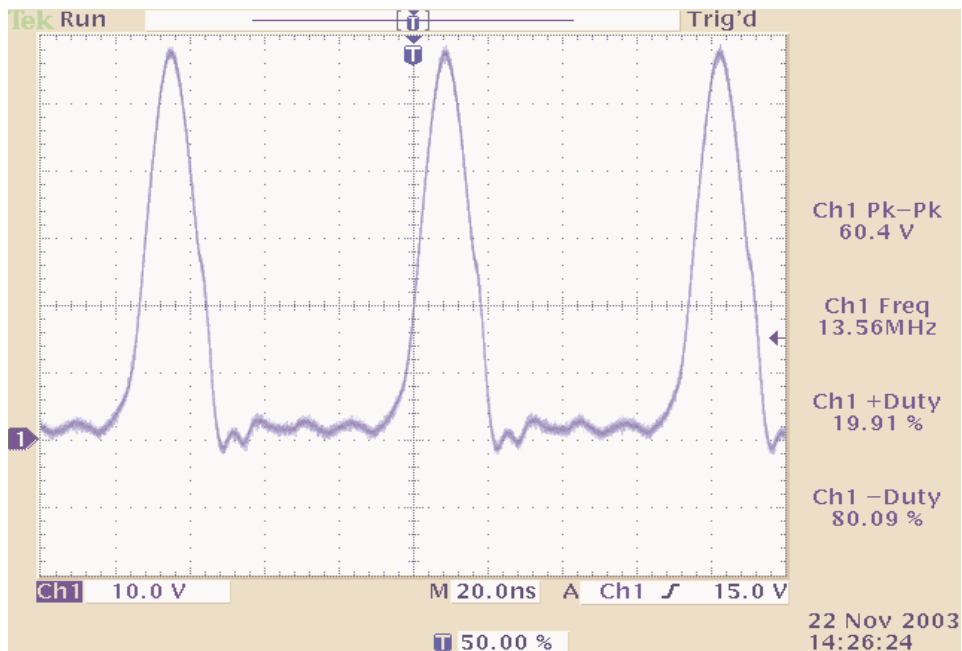

### 1.4.3. Waveform at TP3

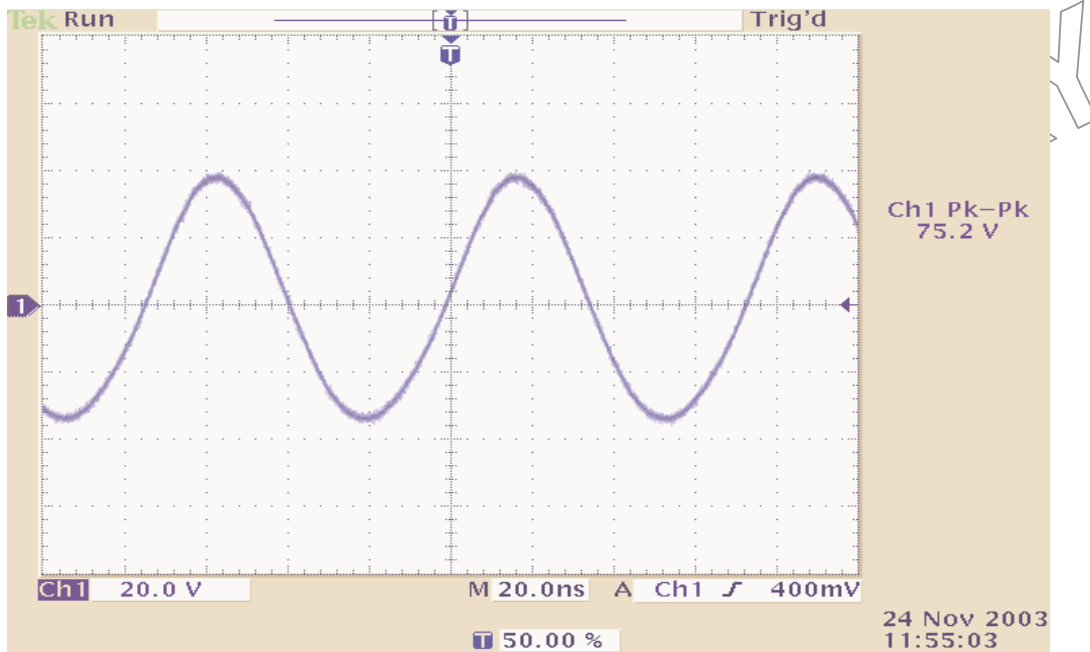

### 1.4.4. Waveform at output

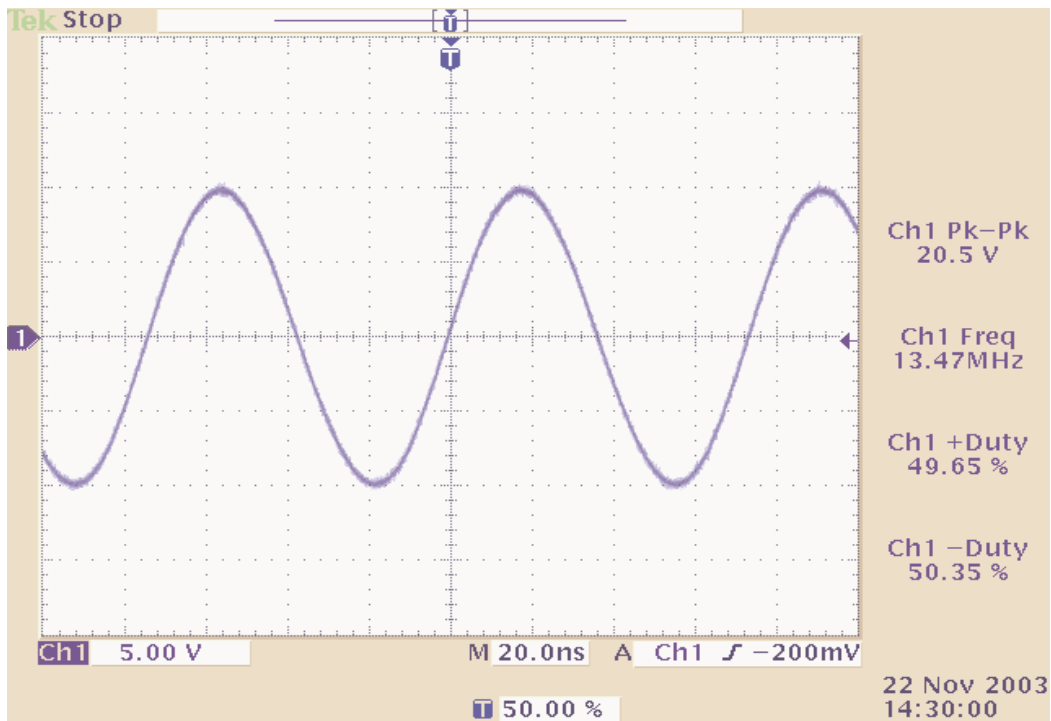

**1.4.5. Transient performance at output with 100% modulation**

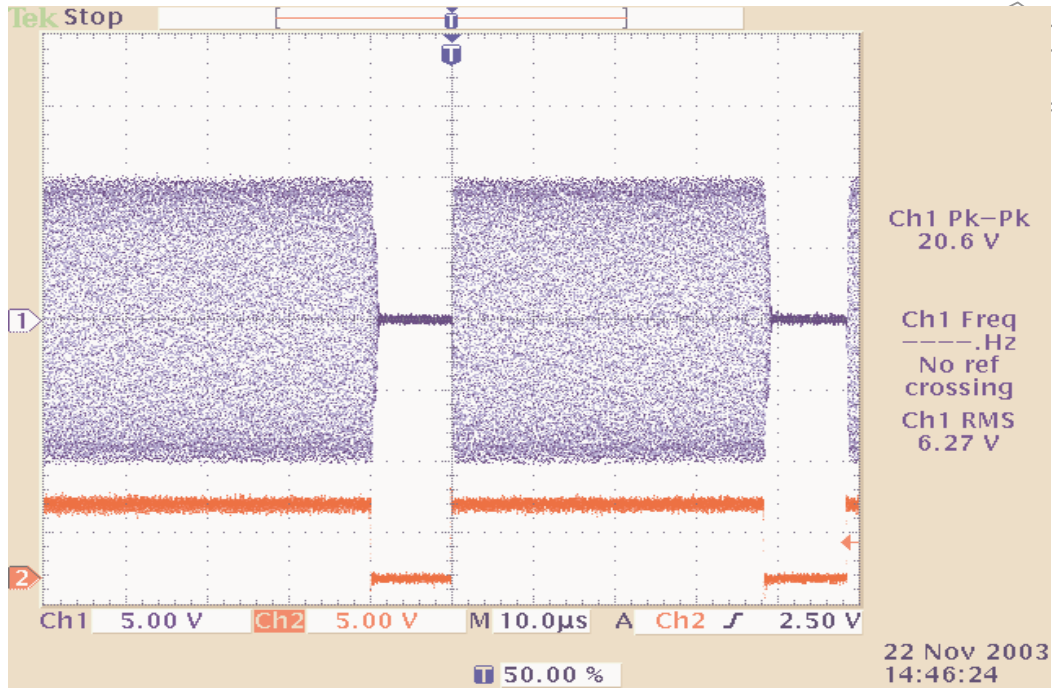

**1.4.6. Output transient performance, low index modulation**

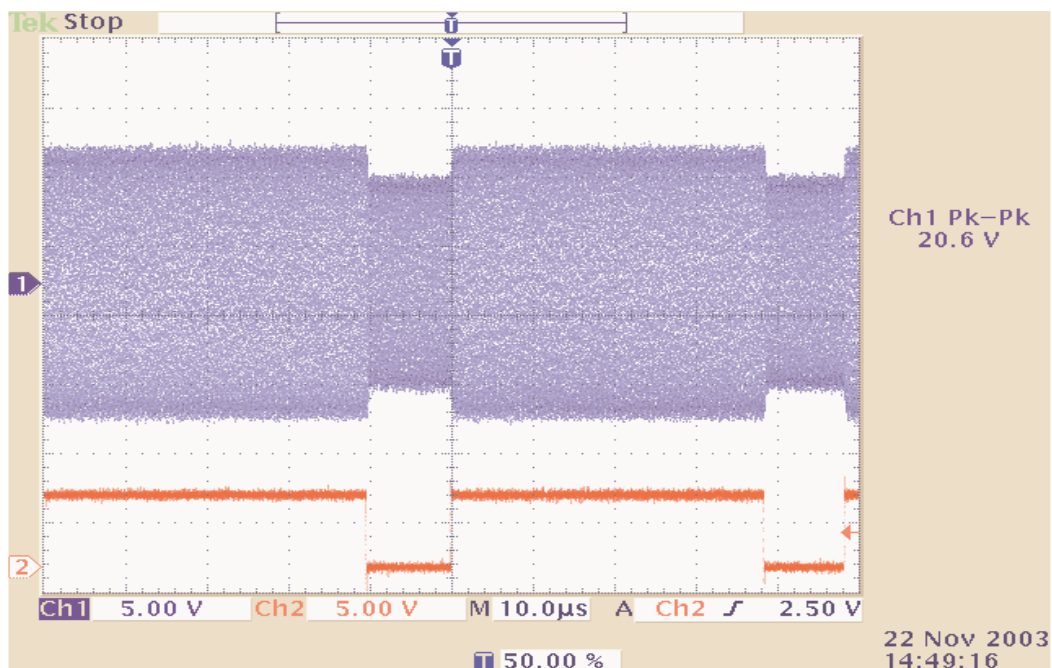

### **1.5. Performance summary**

- Output power: 20 volts peak to peak min into 50 ohms, which is 7.07 volts rms or 1 watt with a 12 volts supply. The power supply voltage can be increased to 15 volts and the output voltage goes up to 26 volts peak to peak, that is 9.2 volts rms or 1.6 watts.
- Total current drain from 5 volts MLX 90121 supply: 60 mA or less.
- Total current drain from 12 volts supply: 0.2 amps or less.
- Power dissipation of MLX90121 internal transistor (simulated): 80 milli-watts or less.
- Power dissipation of M1 (simulated): 200 milli-watts or less.

Please note that all these values apply to room temperature conditions ( 25°C )

## 2. Receiver part

The antenna swing, depending on the transmitted power, varies from 7 to 9V RMS. As the RX input of the chip can only cope with a limited voltage swing some measures have to be taken to limit that swing. There are two different solutions possible.

The first solution requires less hardware and is suited for the situation whereby the reading distance is limited by the field and not by the receiver sensitivity (the case of power hungry micro-processor cards). In that case one can afford to attenuate the receiver signal somewhat. This is the solution requiring only two extra resistors.

In case the reading distance is limited by the receiver sensitivity, one cannot afford to lose any sensitivity at the RX input. Then the use of an external detector that is capacitively coupled with the RX input should be used. This is the solution requiring somewhat more extra hardware.

### 2.1. Solution 1: Attenuation of the RX input.

Here we just use a T type of resistive attenuator to reduce the input swing at the TX pin. This setup will reduce the sensitivity of the receiver part with about 9dB.

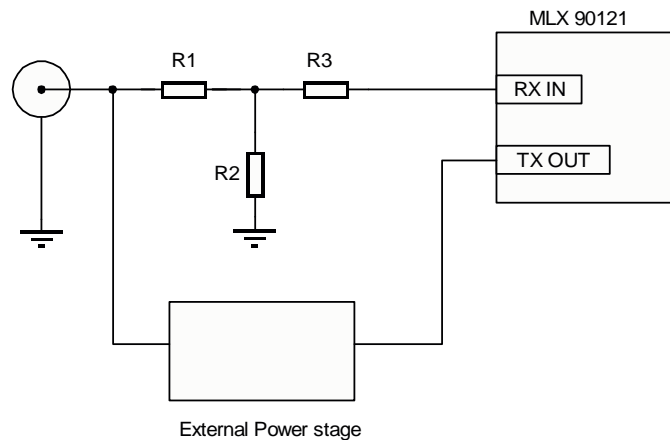

### 2.2. Recommended components

Reference	Value	Comments
R1	1.2 K ohms	
R2	680 ohms	
R3	1.2 K ohms	

Notes:

For higher attenuation decrease R2, for less attenuation increase R2. Leave the values of R1 and R3 unchanged

### 2.3. Solution 2: External detector.

The antenna signal is coupled in with C1, R1 makes a low impedance reference to ground. D1 does the envelope modulation. R2 and C2 are the decay resistor and the smoothing cap respectively. The envelope signal, that has a DC level which is at the peak level of the carrier, is capacitively coupled to the RX input of the MLX90121. The resistor R3 assures a proper biasing of the MLX90121 internal circuitry. This solution needs more components, but does not introduce any receiver attenuation.

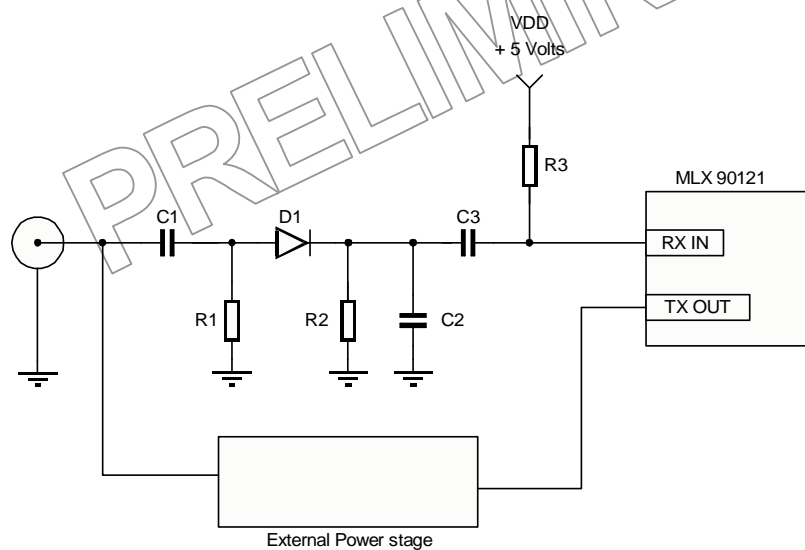

### 2.4. Recommended Components:

Reference	Value	Comments
R1	1.5 K ohms	
R2	22 K ohms	
R3	27 K ohms	
C1	100nF	50 Volts X7R
C2	100pF	50 Volts NPO
C3	2.2nF	50 Volts X7R
D1	BAT 48	Schottky

#### Notes:

With the exception of R3, all components values, proposed here should be considered as a good starting point. Depending on the exact application, the modulation type, etc., further optimization is possible.

R3 is used to set the DC level at the input of the MLX 90121. There is an internal current source in the chip that normally sets the decay time constant when the internal detector is used. The value of R3 is therefore fully optimized and should not be changed.

### **3. Remarks about PCB layout.**

Good RF layout techniques should be used when designing a printed circuit board. It is best to avoid long traces, especially where high frequencies are present. Although not represented on the schematics, a good decoupling is required. It should be placed as close as possible to the cold ends (power supply side) of the coils that provide the DC bias to MOSFETS drains. A 100nF X7R type in parallel with a 10 $\mu$ F solid tantalum is the recommended decoupling network. An additional RF choke and capacitor may be required to comply with applicable EMC stand.

PRELIMINARY

### C. A 1 Watt 5 volts power booster for the MLX90121: Scope

For some applications, single supply operation is a must. In this document, a 1 Watt power booster for the MLX90121, that requires only a single 5 volts power supply, is described. Only standard CMOS high speed logic is required to generate the drive signal to the power stage, which is in fact a high power CMOS inverter. Furthermore, the output matching circuit can be reduced to a bare minimum of two components, reducing circuit complexity and cost.

#### 1. Application schematic

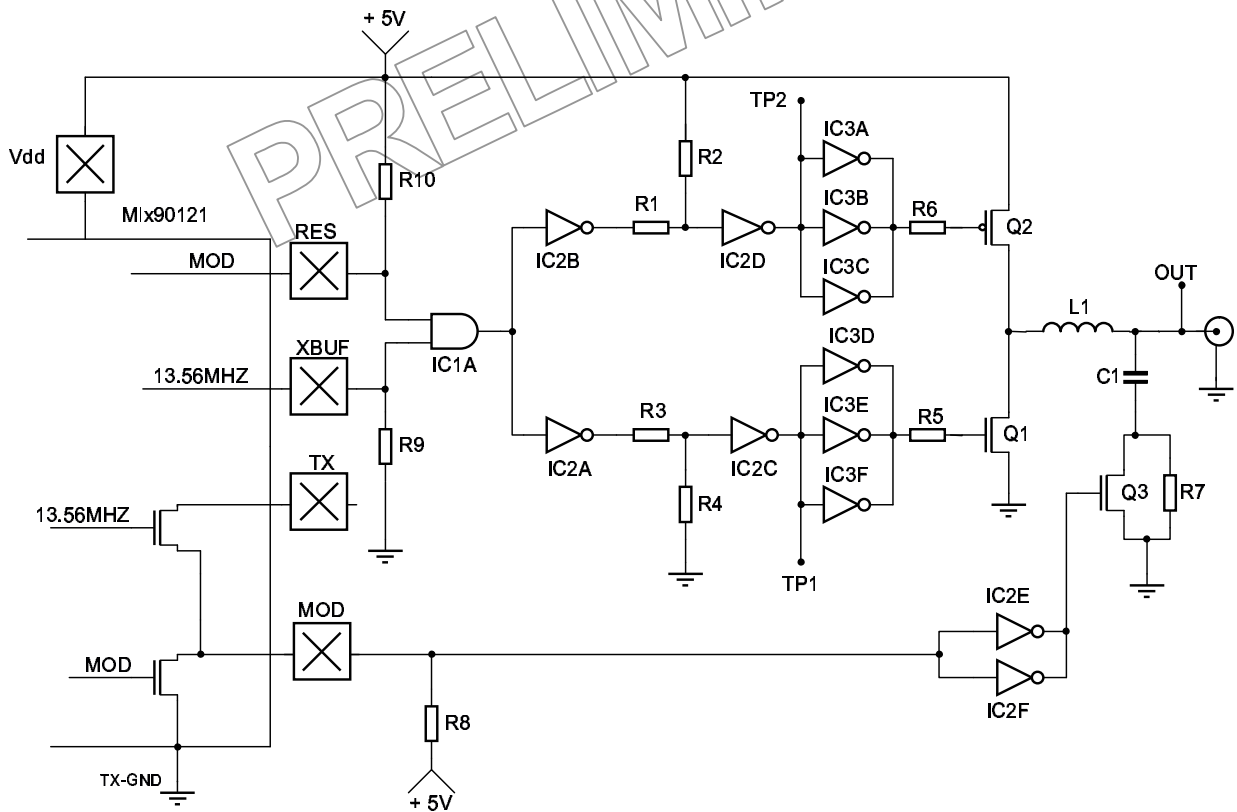

### 1.1. Recommended Components:

Reference	Value	Comments
R1,R2,R3,R4	See text	
R5, R6	4.7 ohms	5% or better
R7	See text	
R8	2.2 K ohms	5% or better
R9, R10	10 K ohms	5% or better
C4	5-50 pF variable	100Volts
IC1	74 AC 08	
IC2, IC3	74 AC 04	
Q1, Q2, Q3	FDC 6327C	FAIRCHILD
L1	130 nH	See note 1
C1	1 nF	See note 2

Notes:

Minimum current rating: 1 Amp.  
Recommended component is [COILCRAFT "Maxi Spring"](#) part number 132-11SM.

Use only a very low loss capacitor. Current rating is the same as L1. A MICA capacitor is recommended. ([Cornell Dubilier](#), [Arco](#) ). If you prefer ceramic, you can purchase low loss RF ceramic power caps from [ATC](#).

## 2. Theory of operation and design guidelines

### 2.1. Theory of operation.

In order to reduce the current drain to a minimum, we do not use the power stage of the MLX90121. Instead, we take advantage of the clock output (XBUF, pin 8). From this point, we generate two independent drive signals that will be used by the final power inverter formed by the complementary pair Q1, Q2. Components R1, R2, R3, R4, are used to define the duty cycle of the signals applied to the gates of the PMOS transistor Q1 and the NMOS transistor Q2, respectively. This configuration creates a non-overlapping gate drive for the transistors Q1 and Q2, avoiding excessive power dissipation. By adjusting independently the duty cycle of the drive signal applied to each gate, we can fine tune the amplifier to obtain the best power efficiency.

Three 74AC04 gates are connected in parallel to generate for each power FET the gate drive. Use of the 74AC family is required as it has enough fan-out to directly drive the gates of Q1 and Q2 that have a fairly large capacitance. ( about 330 pF )

R5 and R6 are connected in series with the gates. This reduces slightly the overall efficiency, but it avoids parasitic oscillations. The optimal resistor value is layout dependent; some kind of fine tuning could be required.

The output matching circuit is implemented by L1 and C1. Together, they form a low- to high impedance converter. L1 and C1 must have very low losses. L1 sees an AC current of about 2 Amps peak-peak. When substituting the recommended L1 from Coilcraft by some other component, you have to take care of its current rating. The same holds true for C1.

In order to meet applicable electromagnetic compatibility standards, an additional low pass filter maybe required.

Modulation in 100% mode is achieved by using a special output pin ( RES, pin 18) of the MLX90121 from which modulation pulses can be recovered. For info on how to configure the MLX90121 to do this, please contact Melexis. These pulses are applied to the 74AC08 gate to key the carrier on and off. R10 is a pull up resistor that makes sure that when the RES pin goes to a high impedance state, the carrier from XBUF still drives the amplifier. R9 is a pull down intended to make sure that when the carrier is off, the DC voltage at the output antenna connector is 0 volts. Please note that the antenna output is DC coupled. This is not a problem since most RFID antennas have a DC blocking cap somewhere in the signal path. To check the signal power on a dummy load ( 50 ohms resistor ), one must insert a DC blocking capacitor in series with the output. Two high quality plastic film 47 nF capacitors placed in parallel will do the job.

Low index modulation is achieved by means of an additional power MOSFET Q3. Since the normal output power stage of the MLX90121 is unused, the RMOD output is pulled-up with resistor R8 to Vcc, generating a modulation signal. The value of the pull up resistor has to be kept low enough so that capacitance does not become a problem. A value of 2.2 K gives good results. Two 74AC04 inverter gates are used to drive the gate of Q3 and provide the proper signal polarity. The value of R7 will be layout dependent. One should start to experiment with a value of 1 ohm. A tight tolerance is required (1% or better). The power rating of R7 should be no less than 500 milliwatts.

### **2.2. Fine tuning of the circuit.**

If you plan to use your own layout, some adjustments may be required. The trickiest point is to set the correct value for the duty cycle of each gate. In the first place, one should replace R1, R2, R3, and R4 by two multi turn potentiometers. The lowest possible value must be used for the pot. High ohmic values will dramatically increase the rise and fall times, because of the 74AC04 gate input capacitance. We suggest to use a 2K pot from the BOURNS 3296W series.

To adjust the duty cycle, remove R5 and R6 from the board, tie the PMOS gate to VCC (+ 5 volts) through a 1K resistor, tie the NMOS gate to GND through a 1K resistor, and adjust the duty cycle for each gate to 80%/20% and 20%/80% respectively. Remove the two 1K resistors, put back in place R5 and R6. Monitor at the same time the duty cycle at each gate, the output voltage on an adequate dummy 50 ohms load, and the power supply current. Increase little by little the duty cycle on each gate until the output voltage stops increasing. Go back a little to make sure that you have the best power efficiency. Check the current drain, the power output, and verify Q1 and Q2 power dissipation. Although the FDC6327C case is rated for 1 Watt at 25°C, we recommend having no more than 0.5 Watts total power dissipation for Q1, Q2.

The logic circuits may have slightly different characteristics, depending on their manufacturer. It is better to use only one manufacturer for all the gates. In case of substitution, check again the duty cycle settings.

Use adequate decoupling whenever possible. Place decoupling caps close to the power pins of each IC. Use good quality caps, some ceramic caps have unacceptable ESR values. Most manufacturers provide models and/or simulation tools that let you examine the frequency characteristics of their products. Since we have very fast edges in the circuit, it will be necessary to have a combination of several capacitors to have a proper decoupling at all the frequencies of interest. A low ESR tantalum cap will provide the general low frequency decoupling. For each IC power pin, a 100 nF in parallel with a 100 pF is a good combination. Additionally, the use of RF chokes to isolate the different supply rails is highly recommended. These chokes should have

the highest possible resistive component, since this is the best way to prevent ringing and “communication” between the circuits via the supply rails.

Note:

One should plan in advance adequate test points for the gate drive signals. The best is to have test points where you can plug the scope probe head directly, thereby insuring the best possible monitoring. Using a standard probe ground attachment is NOT an acceptable option. Inductance does matter a lot. If you cannot use specific probe head inserts, the following trick may work. Take a piece of small gage rigid wire. Form a coil spring around the scope probe head where you will find in general the ground connection. Twist both ends on a SHORT length (less than 1.5 centimeters). Solder directly on the ground plane close to the pcb trace you want to monitor the resulting ground attachment. The only requirement is to have planned a plated through hole in the middle of the pcb trace with a drill diameter large enough to accommodate the probe tip pin. Be careful to not break the probe tip!

It is recommended to have the antenna close to the transmitter, by preference on the same board. If this is not possible a 50Ohm coax cable may be used, but care must be taken to the cable length as matching is not a perfect 50Ohm. Performance might then be cable length dependent.

### **2.3. Printed circuit board layout issues.**

The track length between R5, R6 should be kept to an absolute minimum. The same holds true for the tracks that go from the 74AC04 gates to these resistors. If some length cannot be avoided, the trace should be as wide as possible. The width of a 0805 resistor is a minimum. One must always remember that in this application, stray inductors and ringing are the enemies. If too much ringing occurs at the power MOSFETS gates, they may turn on simultaneously. This will affect severely the amplifier efficiency or even destroy it. Use of large ground plane is an absolute necessity. However, it is better to think and plan in advance where the return currents will flow. We are not in the microwave range of frequencies, and it is perfectly acceptable to insert slits in the ground plane in order to channel the return currents paths, and create areas where the ground plane is quiet.

## D. MLX90121: Support of different modulation modes: Scope

This application note is a guide to read transponders with the MLX90121 that use non-standard ISO14443 or 15693 modulation formats.

The different formats described in this application note are the following:

- Base band communication: i.e. communication without sub-carrier
- Applications with a sub-carrier of 212 kHz

Decoding the different modulation types does not require any specific hardware. It only requires a different register configuration setting of the MLX90121.

### 1. Base band communication:

This application note is divided in four parts:

1. Low Data Rates: up to 40 kb/s.
2. Medium Data Rates: around 100 kb/s.
3. High Data Rates: around 200 kb/s.
4. Very High Data Rates: over 400 kb/s.

#### 1.1. Low data rates:

##### 1.1.1. Configuration:

Address	Register	Data
0	AnalogConfig	0x27
1	PowerState	0x01
3	DigitalConfig	0x09
12	LTC	0x01

The encoder has to be programmed according to the application. The decoder (DecoderTimeRef) is not used.

With this configuration the chip is in ASK configuration with a higher comparator threshold to avoid glitches. The result is a pulse on DOUT at each field edge.

##### 1.1.2. Screen captures:

The following captures show the MLX10111 in direct mode. The response is a Bi-phase coded signal at 4 kb/s.

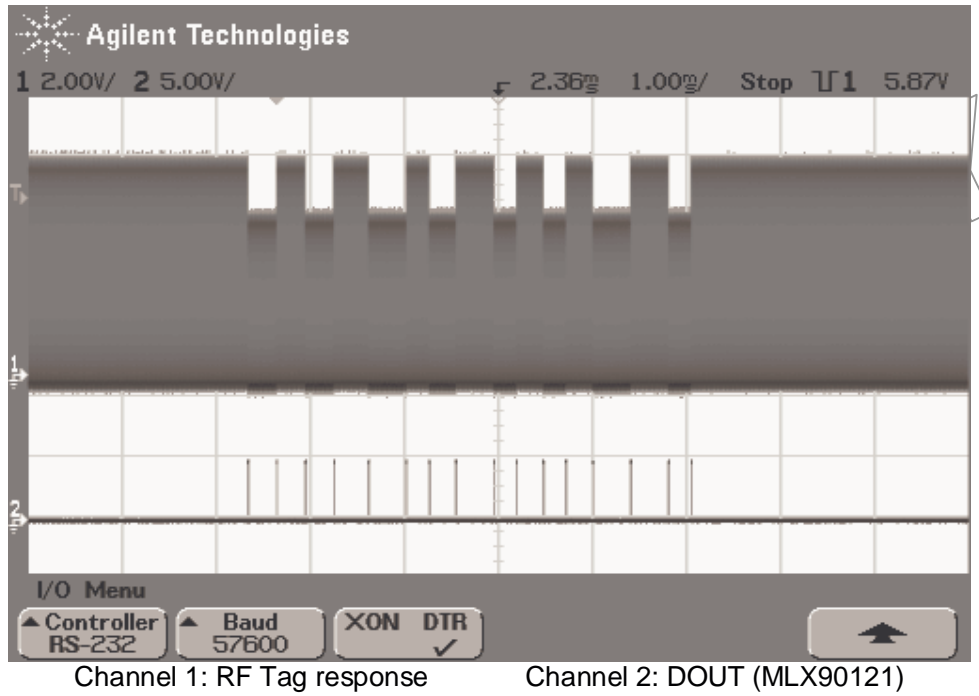

**Figure 1: Byte transmission**

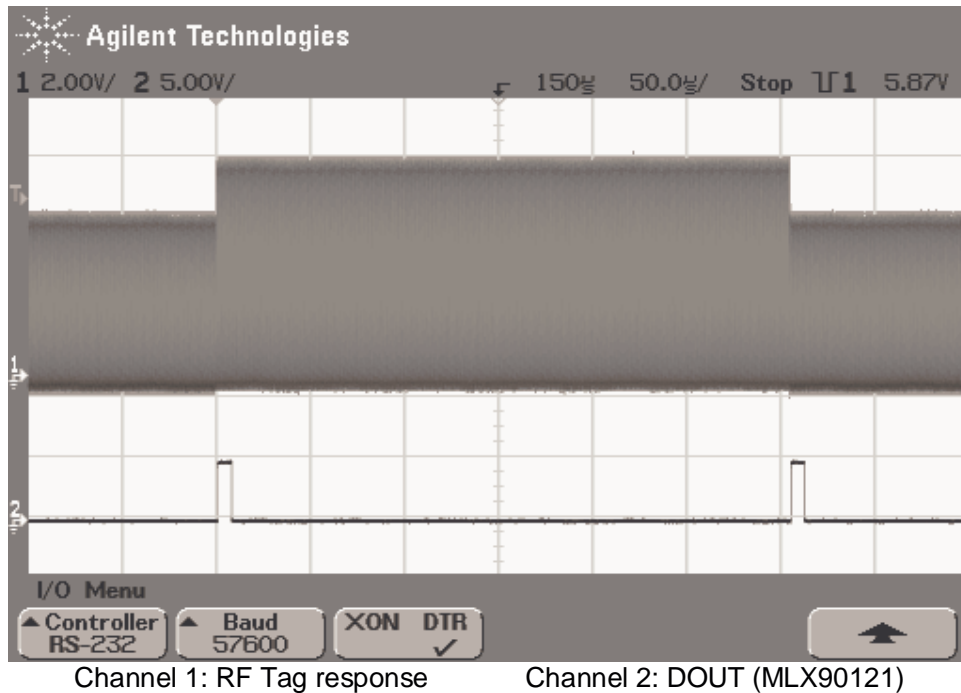

**Figure 2: Zoom to one bit**

Typical pulse duration is 6µs.

The following captures show an ASIC in base band mode. The response is a Manchester coded signal at 26.5 kb/s.

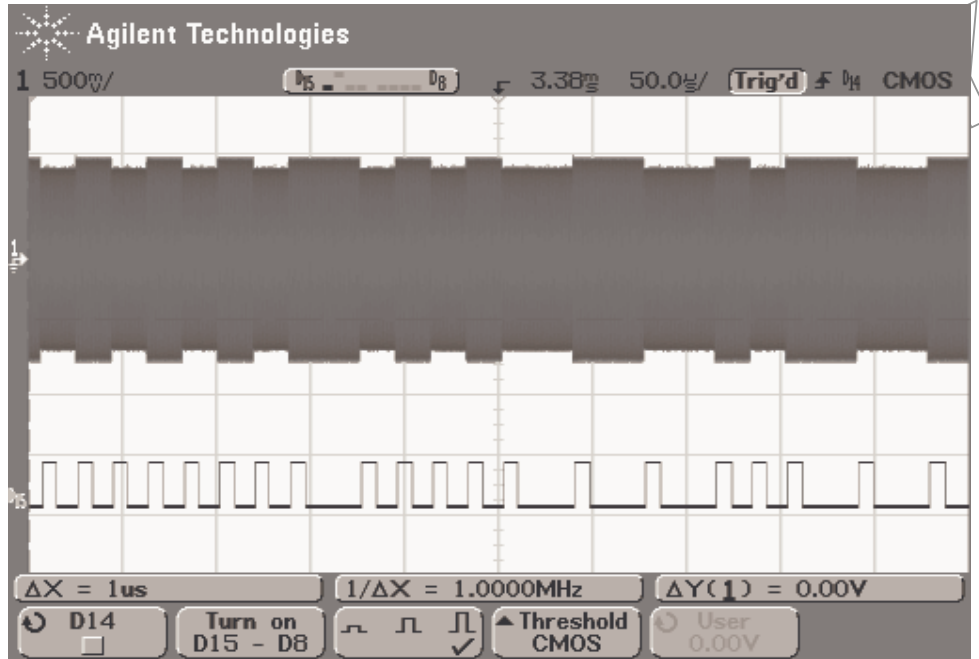

Channel 1: RF Tag response      D15: DOUT (MLX90121)

**Figure 3: Block reading**

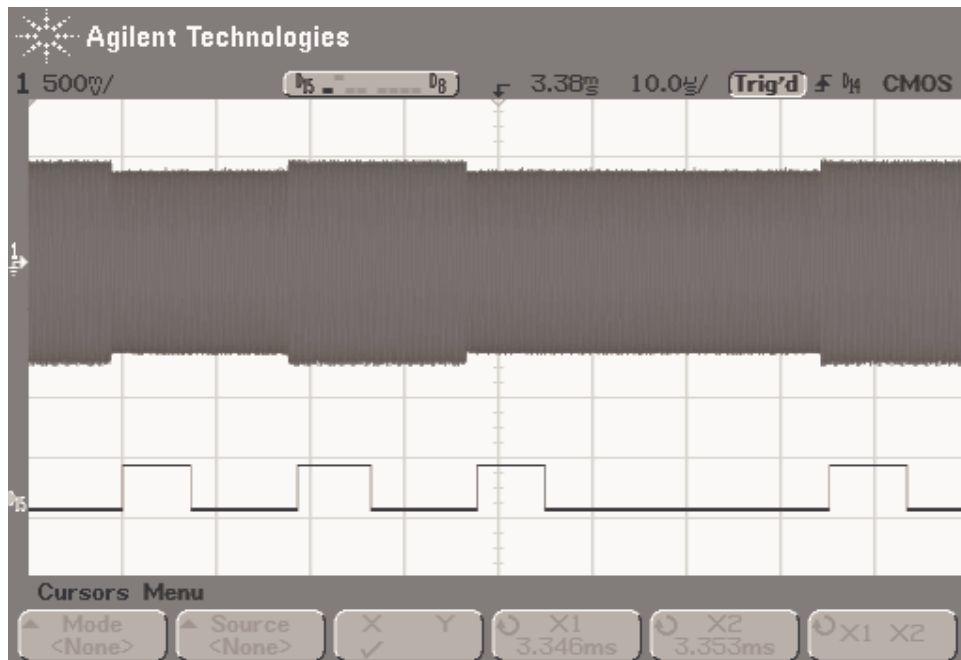

Channel 1: RF Tag response      D15: DOUT (MLX90121)

**Figure 4: Block reading, zoom in**

Because of the differentiating character of the receiver, it generates pulses at the rising and falling edges of the modulation signal. Typical pulse duration is 7µs. By software, the complete signal can be properly decoded.

**Note:** it is not possible to decode NRZ (Non Return to Zero) coded signals.

## 1.2. Medium Data Rates

### 1.2.1. Configuration

Address	Register	Data
0	AnalogConfig	0x37
1	PowerState	0x01
3	DigitalConfig	0x09
12	LTC	0x00

The encoder has to be programmed accordingly to the application. The decoder (DecoderTimeRef) is not used.

With this configuration the chip is in ASK configuration. The result is a pulse on DOUT at each field edge.

### 1.2.2. Screen captures:

The following capture shows the MLX10111 replying in BPSK at about 106 kb/s.

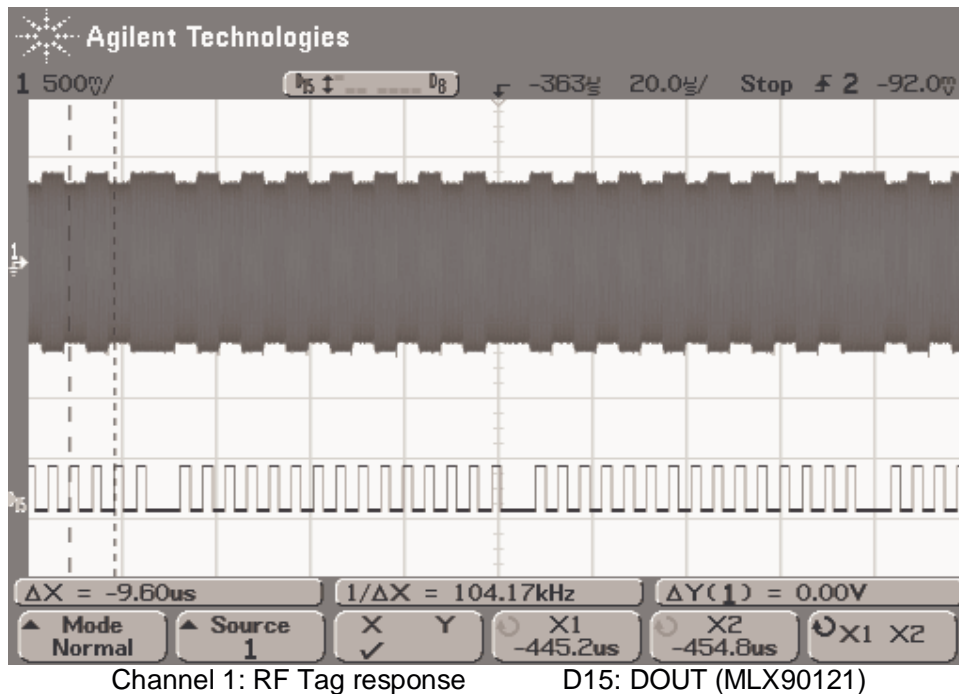

**Figure 5: Pattern response at 104 kb/s**

Here also the receiver chain shows its differentiating character. The phase shifts can be very easily extracted out of the pulse pattern as shown in previous scope screen capture.

**Note:** it is not possible to decode NRZ (Non Return to Zero) coded signals.

### 1.3. High Data Rates:

#### 1.3.1. Configuration:

Address	Register	Data
0	AnalogConfig	0x23
1	PowerState	0x01
3	DigitalConfig	0x0B
12	LTC	0x00

The encoder has to be programmed accordingly to the application. The decoder (DecoderTimeRef) is not used.

With this configuration the chip is in FM configuration. The low pass filters and gain blocks have been added.

#### 1.3.2. Screen capture:

The following capture shows the MLX10111 replying in BPSK at about 212 kb/s.

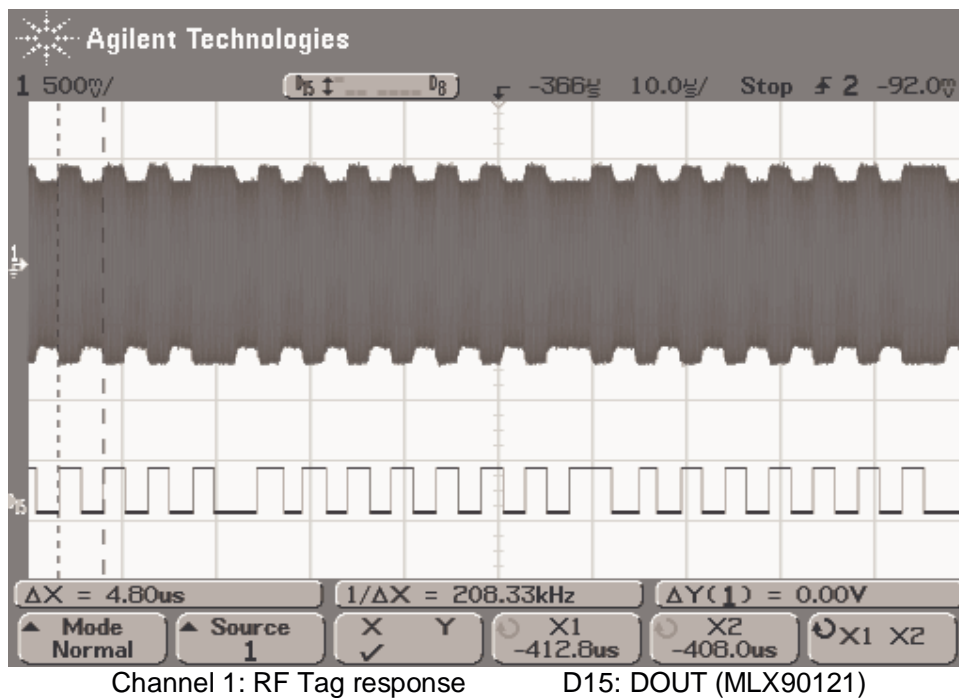

**Figure 6: Pattern response at 208 kb/s**

Here again phase shifts can be easily recovered from the digital signal at Dout.

### 1.4. Very High Data Rates

#### 1.4.1. Configuration

Address	Register	Data
0	AnalogConfig	0x27
1	PowerState	0x01
3	DigitalConfig	0x0B
12	LTC	0x00

The encoder has to be programmed accordingly to the application. The decoder (DecoderTimeRef) is not used.

With this configuration the chip is in FM configuration.

#### 1.4.2. Screen captures:

The following captures show the MLX10111 replying in BPSK at about 424 kb/s and 848 kb/s.

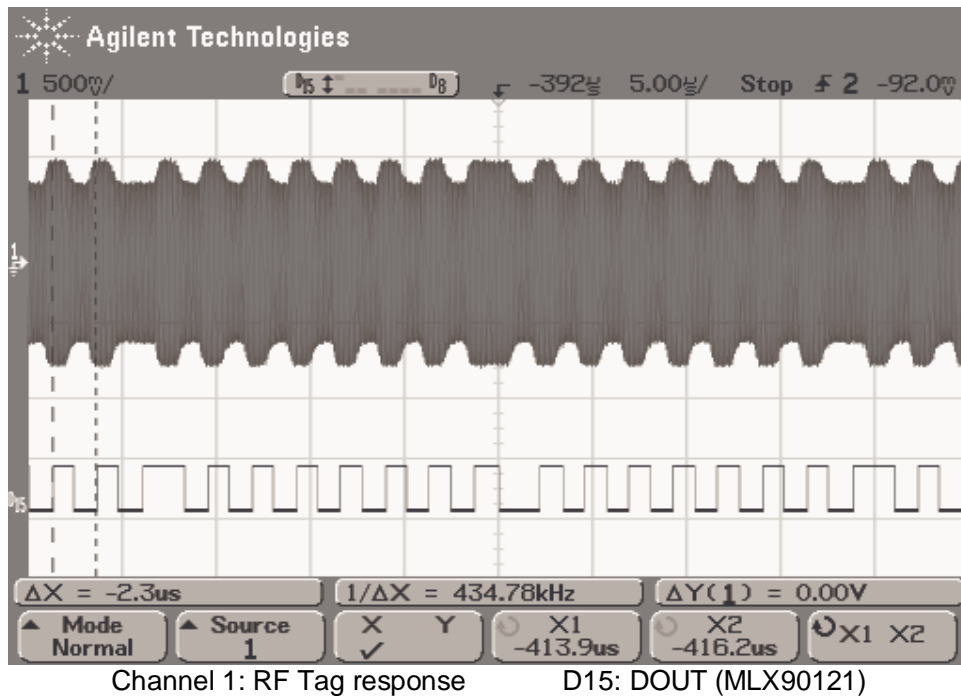

**Figure 7: Pattern response at 434 kb/s**

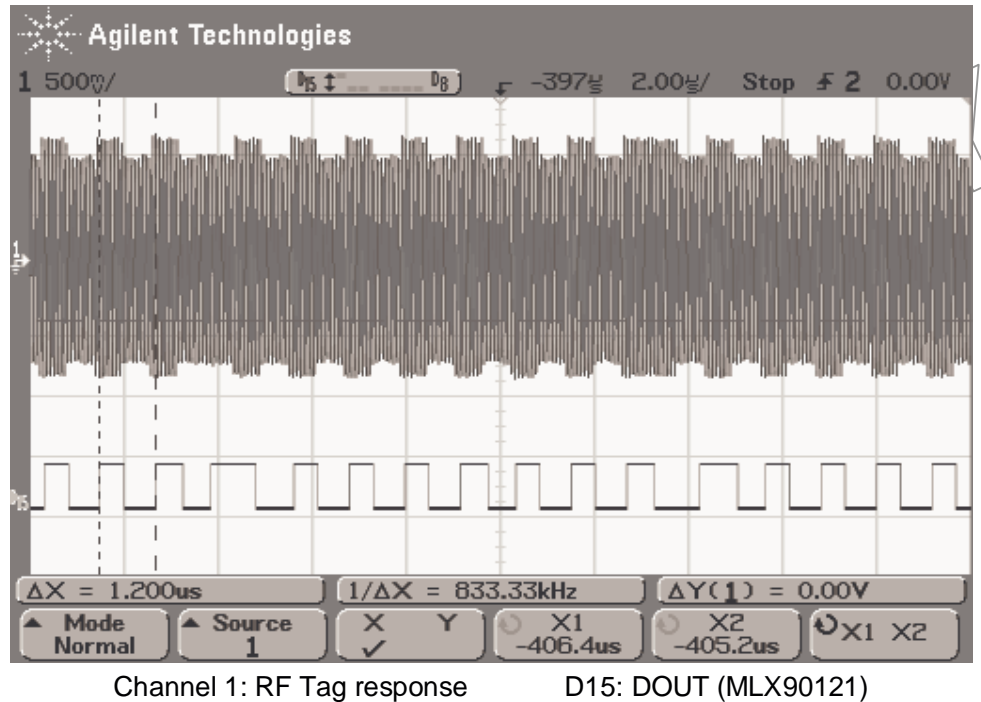

**Figure 8: Pattern response at 833 kb/s**

Here again phase shifts can be easily recovered from the digital signal at Dout.

**Note:** For frequencies > 800 kHz, the digital output starts to be distorted. Still the signal can be decoded.

## 2. Applications with a sub-carrier of 212 KHz:

### 2.1. Configuration:

Address	Register	Data
0	AnalogConfig	0x27
1	PowerState	0x01
3	DigitalConfig	0x09
12	LTC	0x00

The encoder has to be programmed accordingly to the application or the chip can be used in direct mode. The decoder (DecoderTimeRef) is not used.

With this configuration the chip is in ASK configuration, high baud rate.

**2.2. Screen captures:**

The following captures show the MLX10111 response and the MLX90121 digital output.

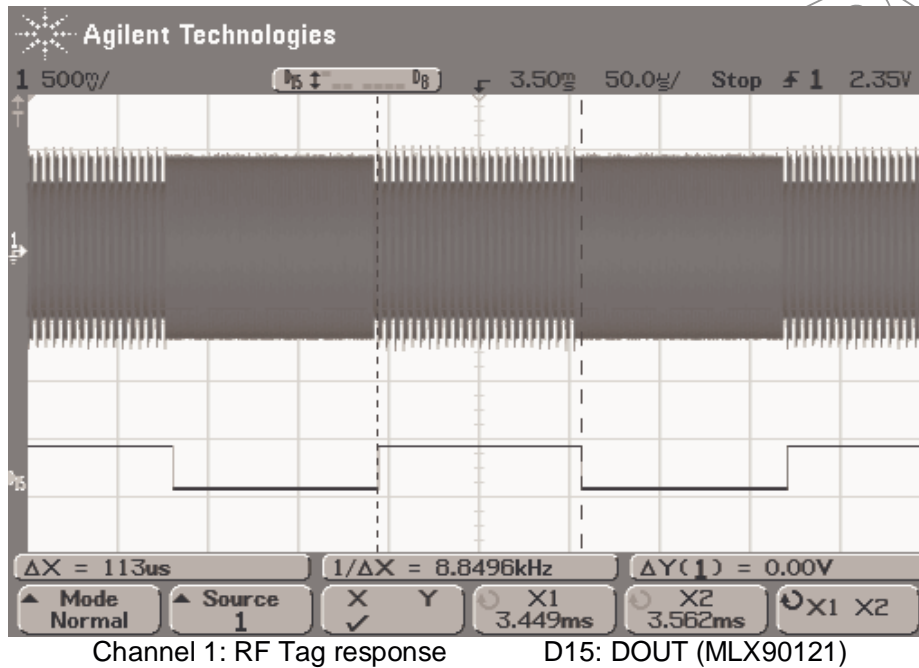

**Figure 9: Reception example**

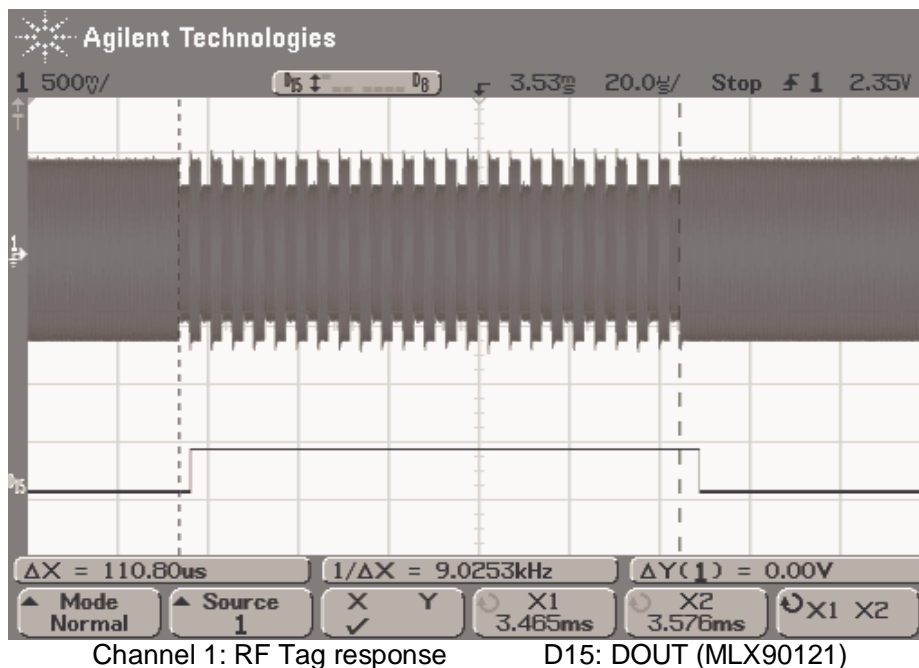

**Figure 10: Bit '1'**

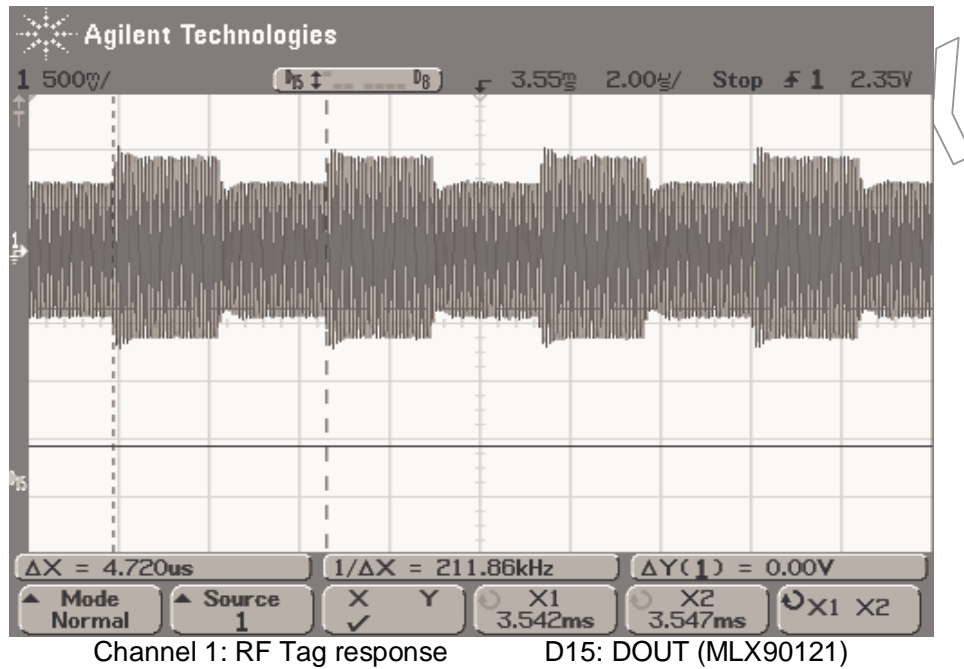

**Figure 11: Zoom on the subcarrier**

The sub-carrier envelope can be easily recovered from the Dout output of the MLX90121.

### 3. Conclusion

The MLX90121 supports ISO standard 14443A/B and 15693 protocols. In addition, its high versatility allows for handling of other custom protocol, like base band modulation and modulation at a 212 kHz sub-carrier.

## E. Progressive field increase for the MLX90121: Scope

This application note is a design guide to provide a means of controlling the radio frequency field intensity when a command is sent to a tag. It has been found that some RFID tags do not operate properly when the field intensity reaches its maximum in a very short time. In order to solve this issue, we propose a universal solution, applicable to both the standard and power boosted version, where the characteristics of the progressive field increase sequence can be parameterized under software control to achieve the desired performance.

### 1. Standard design (200 mW @ 5 Volts)

#### 1.1. Application schematic

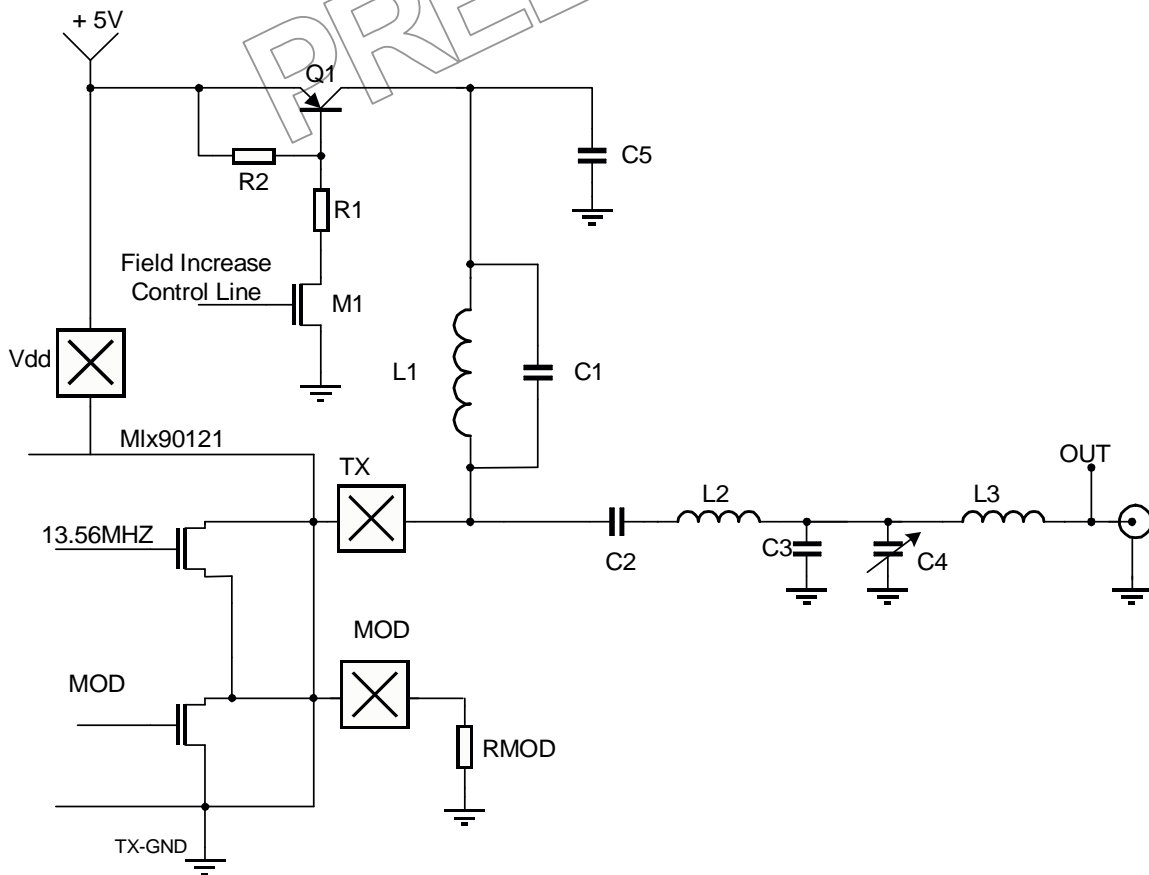

### 1.2. Recommended Components:

Reference	Value	Comments
R1	470 ohms	5% or better
R2	2.2 Kohms	5% or better
M1	BS 170 or PMBF 170	PHILIPS
Q1	FZT 949	ZETEX
C5	4.7 $\mu$ F	Tantalum

Note:

Other components values do not differ from the standard recommended reader schematic.

### 1.3. Theory of operation and design guidelines:

When M1 is switched on, it delivers about 10 milliamps of base current to Q1. Hence Q1 is switched on. To progressively increase the field intensity and therefore obtain a smooth start-up sequence, it is possible to apply short pulses to the gate of M1 and therefore gradually increase the output stage supply voltage and hence the radio frequency field intensity.

In the application software (available on request with the MLX90121 demo board), we have implemented a special command which gives control over 5 parameters for the radio frequency field intensity. To understand their utility, we shall refer to the following timing diagram of the signal applied to the gate of M1 during a typical RFID tag transaction:

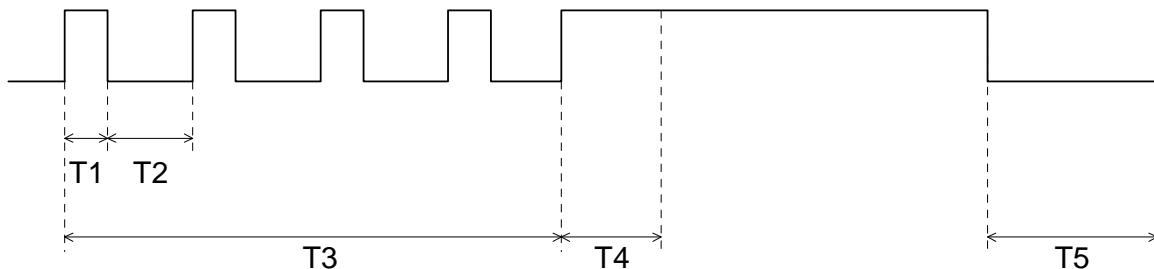

T1 adjusts the pulse width. T2 controls the duty cycle. T3 controls the duration of the smooth power supply ramp up. With these three parameters, the smooth start procedure can be fine tuned, adjusted to a specific design, different values of the power stage supply decoupling capacitor, etc...

The main voltage regulator of the application board has a response time to the current surge during the field increase. Because of that, the maximal field intensity is not immediately reached. In order to provide an optimal communication performance during the transaction with the tag, an additional delay T4 is introduced, so that no modulation is applied to the radio frequency field before the end of the main power supply voltage regulator settling.

After the end of the transaction with the tag, the gate of M1 goes low, effectively switching off the power stage supply. However, since the power stage uses a large decoupling capacitor ( C5 on above schematic), it will take a long time before its charge is dissipated if the carrier drive inside the MLX90121 is shut-off at the same time. To remedy this situation, T5 introduces a delay between the instant at which M1 and Q1 are switched off, and the moment where the MLX90121 internal carrier drive signal is also switched off. During the time T5, the power stage is still driven, and discharges C5 rapidly. At the expiration of the T5 delay, one should send the carrier off command to the MLX 90121 to end the RFID transaction.

An additional note about capacitor C5 is. Optimal would be to use a high quality ceramic or plastic film capacitors. Unfortunately, such components are bulky and may be also hard to find. A solid tantalum capacitor will do the job. However, its transient performance will be much worse, and this will severely affect the cleanliness of the output stage supply voltage during the initial ramp up phase. Experimenting with T1, T2 and T3 should yield an acceptable performance.

## 1.4. Oscilloscope screen captures

### 1.4.1. Overview of complete sequence

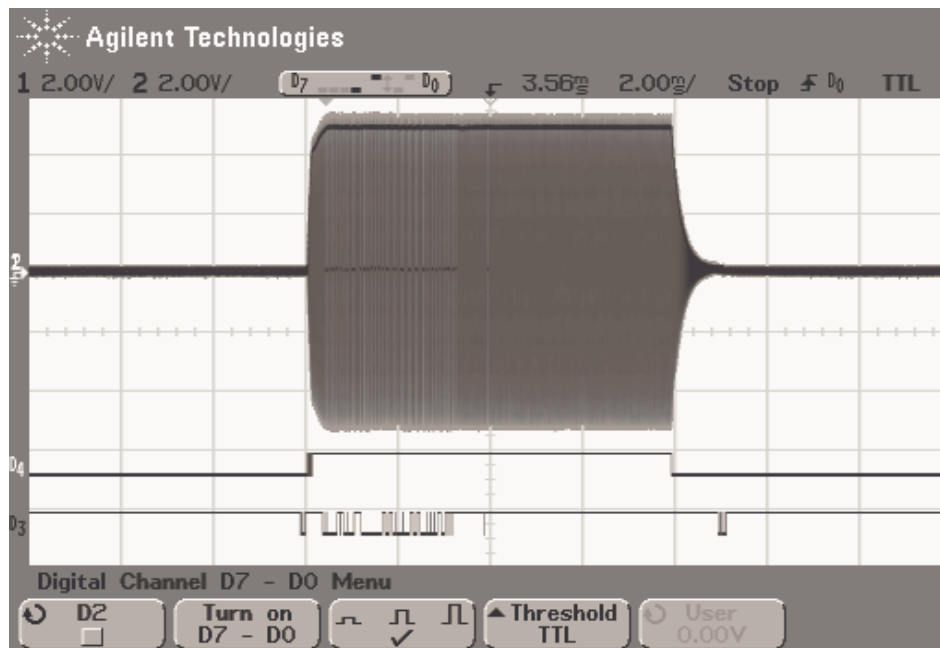

Channel one is the RF signal at the antenna connector.  
Channel two is the power supply voltage of the power stage.  
D3 is the command line of the MLX90121  
D4 is the control line of M1 of this application schematic.

**1.4.2. Detail of start up sequence:**

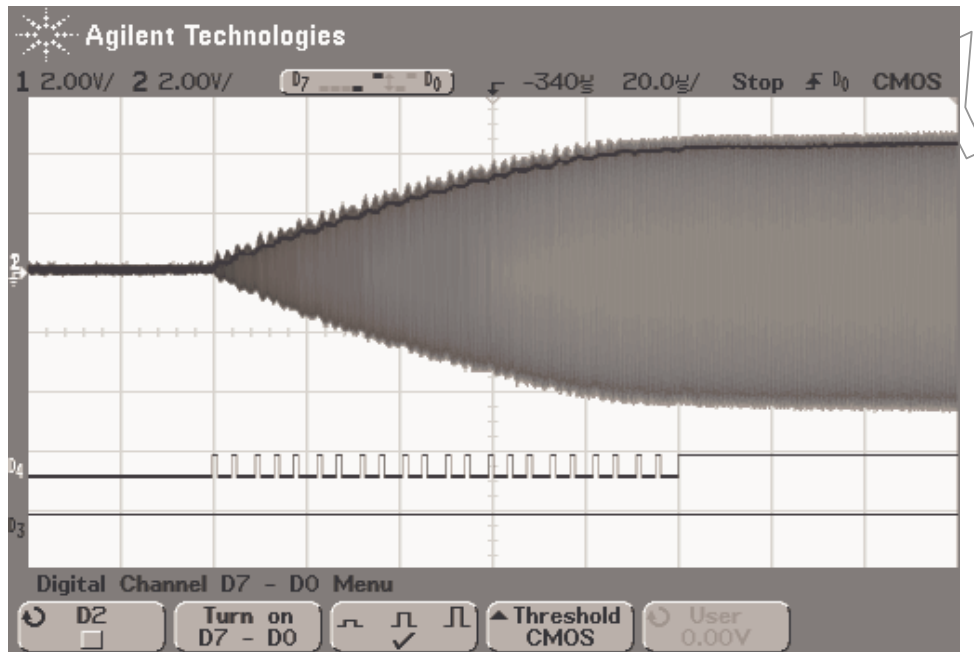

**1.4.3. Detail of main voltage regulator settling effect:**

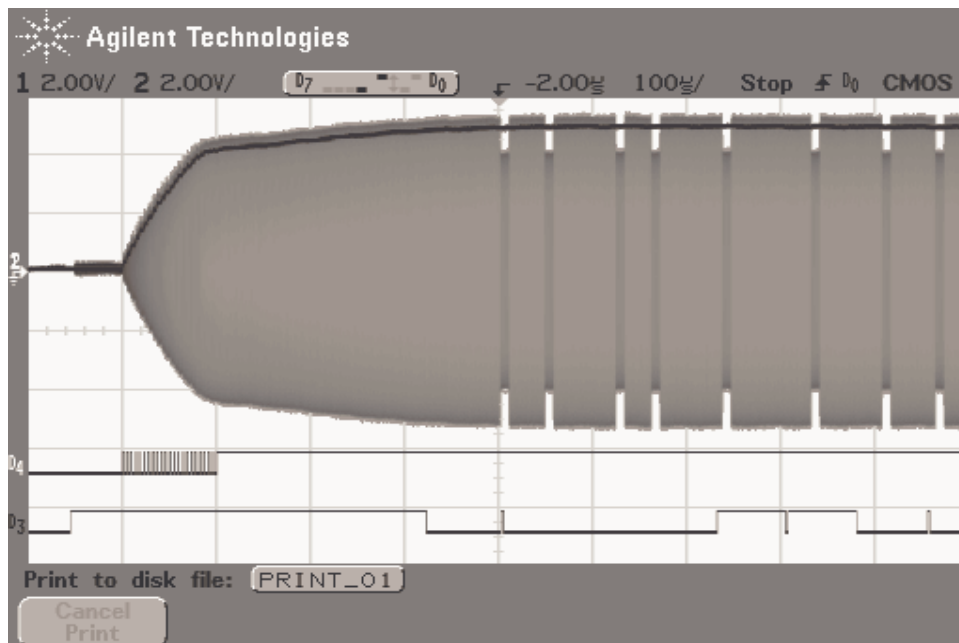

As can be seen on this screen capture, the main voltage regulator takes about 300 microseconds to recover from the initial current surge. Therefore, we have adjusted the value of T4 accordingly, so that the first modulation pulse does not occur before this time.

**1.4.4. End of RFID transaction:**

On this first screen capture, we have adjusted T5 so that the carrier off command is issued to the MLX90121 1 millisecond after M1 is switched off. The continued carrier drive on the output power stage discharges its filtering capacitor, C5, during that time.

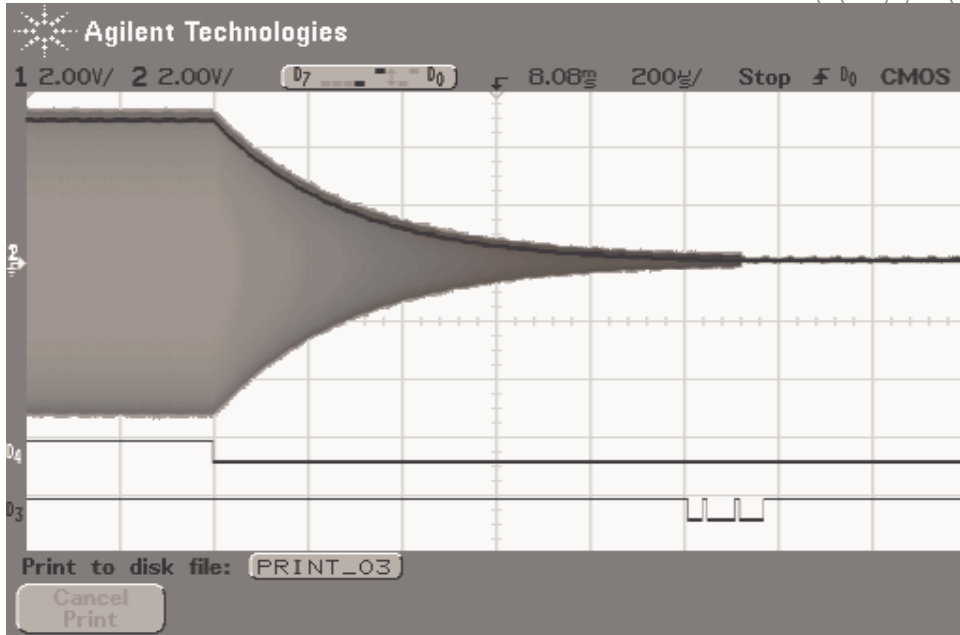

On the following screen capture, one can see what happens when the carrier off command is sent to the MLX 90121 immediately after the output power stage supply has been switched off: The supply voltage remains high for a very long time since in principle, there is not current drain.

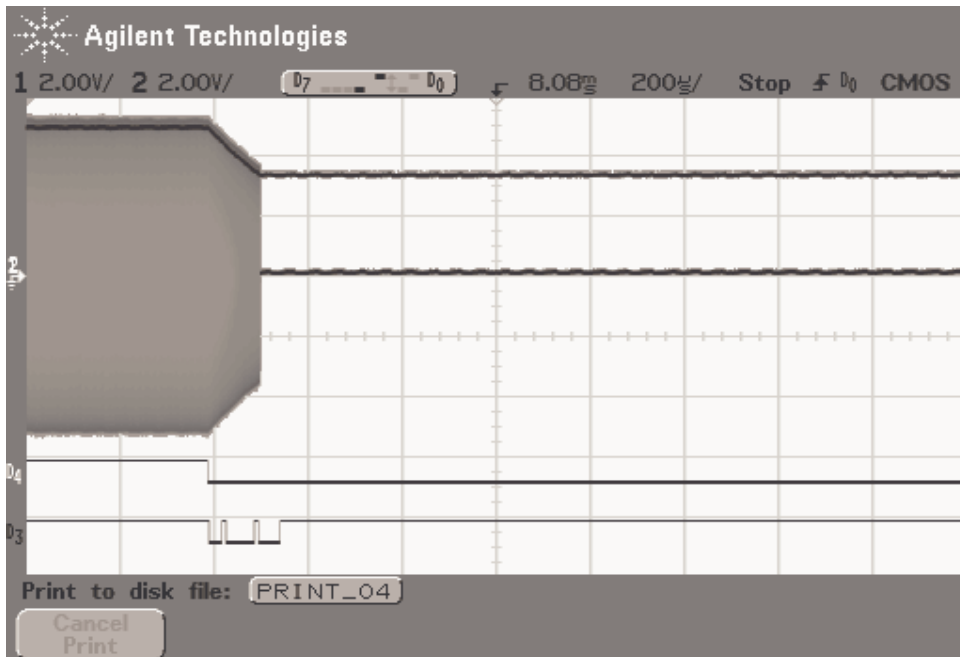

## 2. Power booster configuration ( 1 Watt @ 12 Volts )

For the description of the MLX90121 12V power booster, we refer to the corresponding application note.

### 2.1. Application schematic

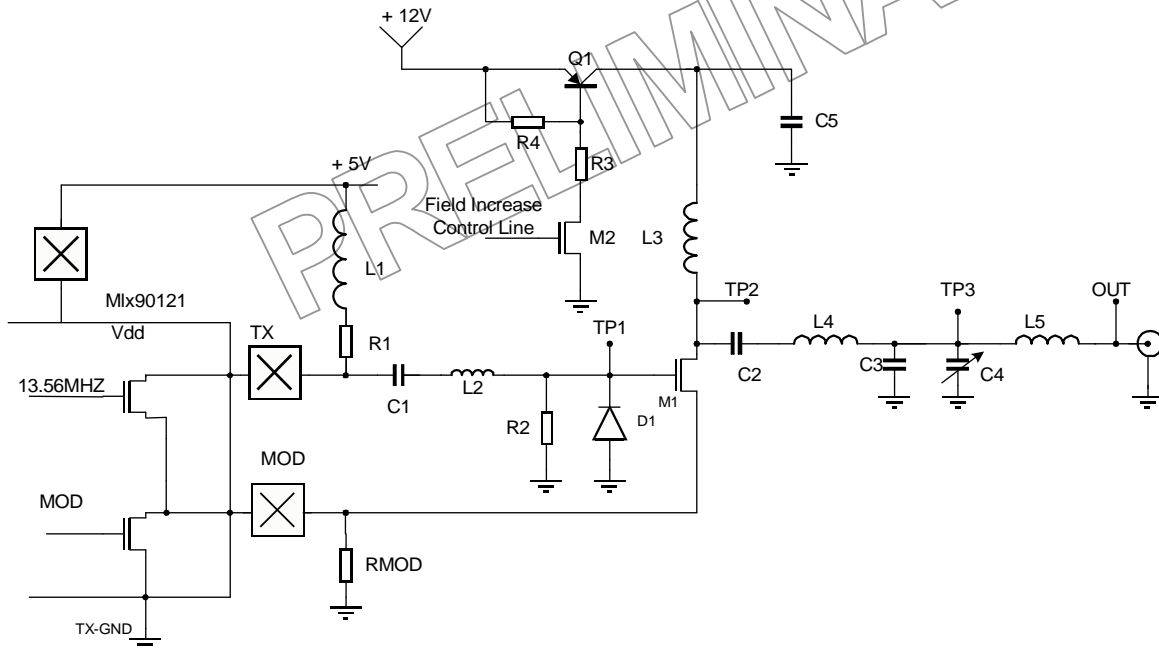

### 2.2. Recommended Components

Reference	Value	Comments
R3	1.2 Kohms	5% or better
R4	2.2 Kohms	5% or better
M2	BS 170 or PMBF 170	PHILIPS
Q1	FZT 949	ZETEX
C5	4.7 $\mu$ F	Tantalum

#### Notes:

Other components values do not differ from the passive matching power boost reader schematic.

Since the 5 volts supply line is not controlled, the MLX90121 internal power transistor is energized. Therefore, during the discharge time T5, when the booster power supply is completely switched off, the antenna signal will not be completely zero because some capacitive feed through will occur from the output stage of the MLX9012. The antenna signal during this period amounts to less than 400 millivolts into 50 ohms load. After T5, the carrier will be switched off inside the MLX90121 which will remove any antenna signal.

## F. A modulation index switch for the MLX90121: Scope

This application note is a design guide to adjust the modulation depth of the MLX 90121. In the low modulation index mode, the ISO 14443 standard requires a typical modulation depth of 11 %, whereas the ISO 15693 standard requires 15 %. In order to make a multipurpose reader, one should be able to switch between these two modulation indexes. Two different designs will be considered. The first one is the standard application schematic with 200 mW output power @ 5 Volts. The second is the 1 Watt power booster described in the corresponding application note.

### 1. Standard design (200 mW @ 5 Volts)

#### 1.1. Application schematic

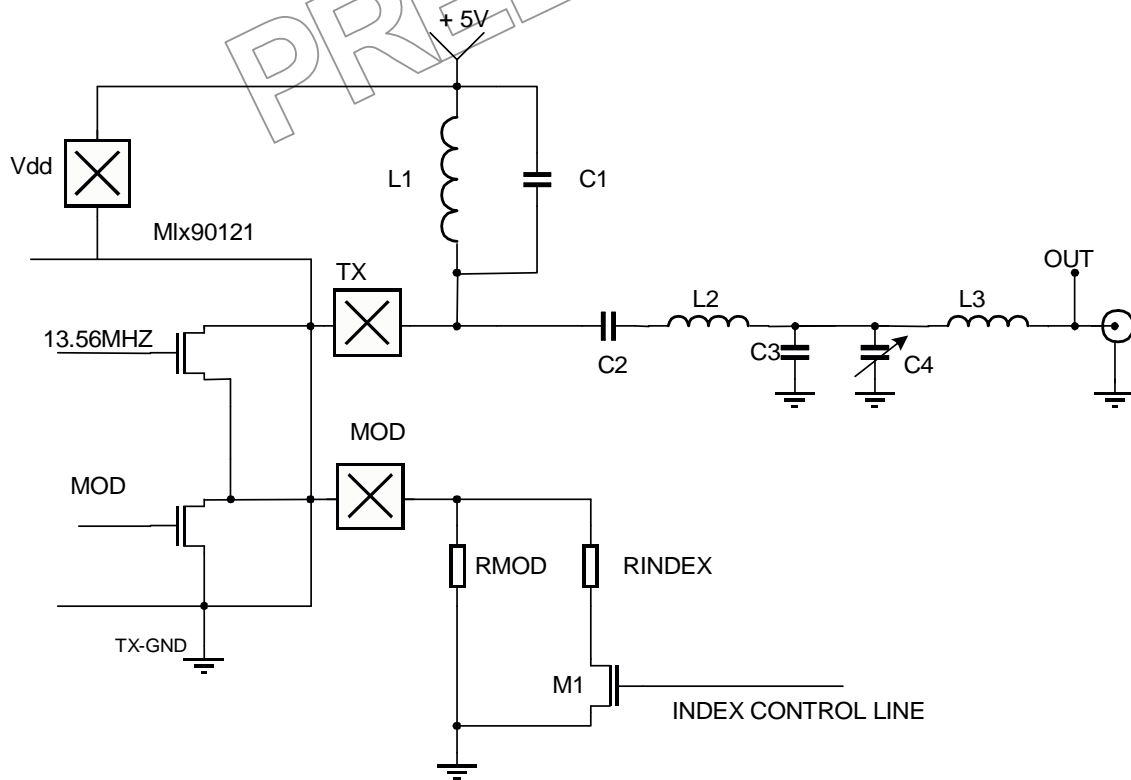

#### 1.2. Recommended Components:

Reference	Value	Comments
RMOD	12 ohms	1% or better
RINDEX	51 ohms	1% or better
M1	BS 170 or PMBF 170	

Note:

Other components values do not differ from the standard recommended reader schematic.

### 1.3. Theory of operation and design guidelines

When M1 is switched on, it places RINDEX in parallel to RMOD, thereby effectively reducing the modulation depth. RMOD should be selected to achieve the typical modulation depth for the ISO 15693 standard (15 %) with M1 switched off. RINDEX should be selected to reach the typical modulation depth of the ISO 14443 standard (11 %) with M1 switched on. The index control line, that is the gate of M1, should be driven by a dedicated micro controller line under appropriate software control.

### 1.4. Waveforms at the antenna connector

#### 1.4.1. ISO 15693, M1 switched off

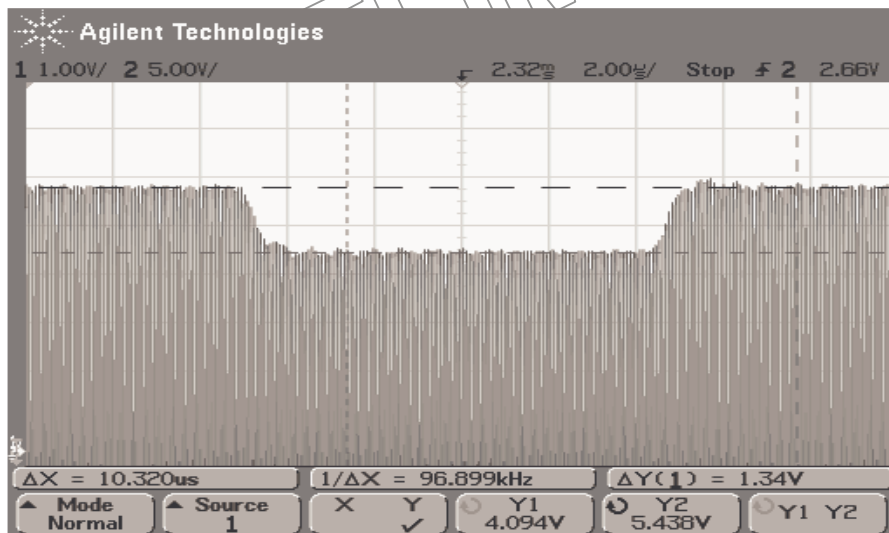

Modulation depth according to scope cursors measurements:  $m = (Y2-Y1) / (Y2+Y1) = 14.1 \%$

#### 1.4.2. ISO 14443, M1 switched on:

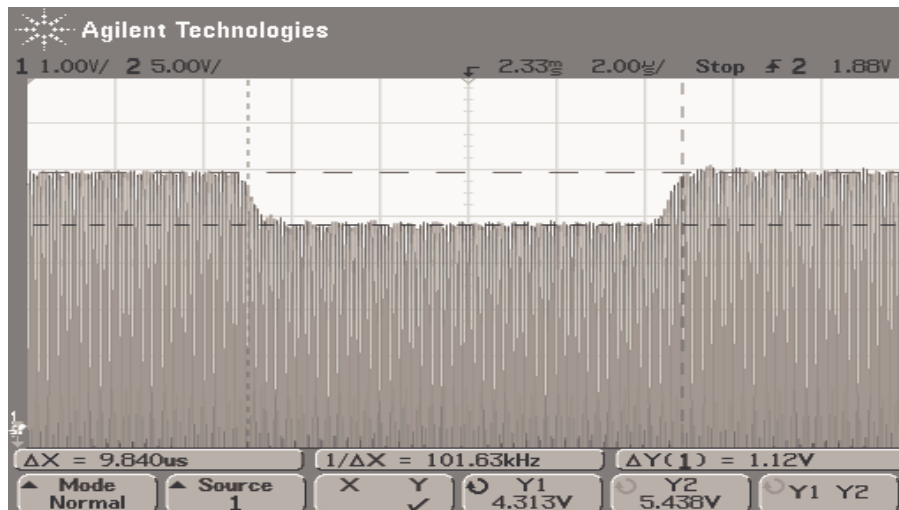

Modulation depth according to scope cursors measurements:  $m = (Y2-Y1)/(Y2+Y1) = 11.5 \%$

## 2. Power booster configuration (1 Watt @ 12 Volts)

For the description of the 12V power booster we refer to the corresponding application note.

### 2.1. Application schematic

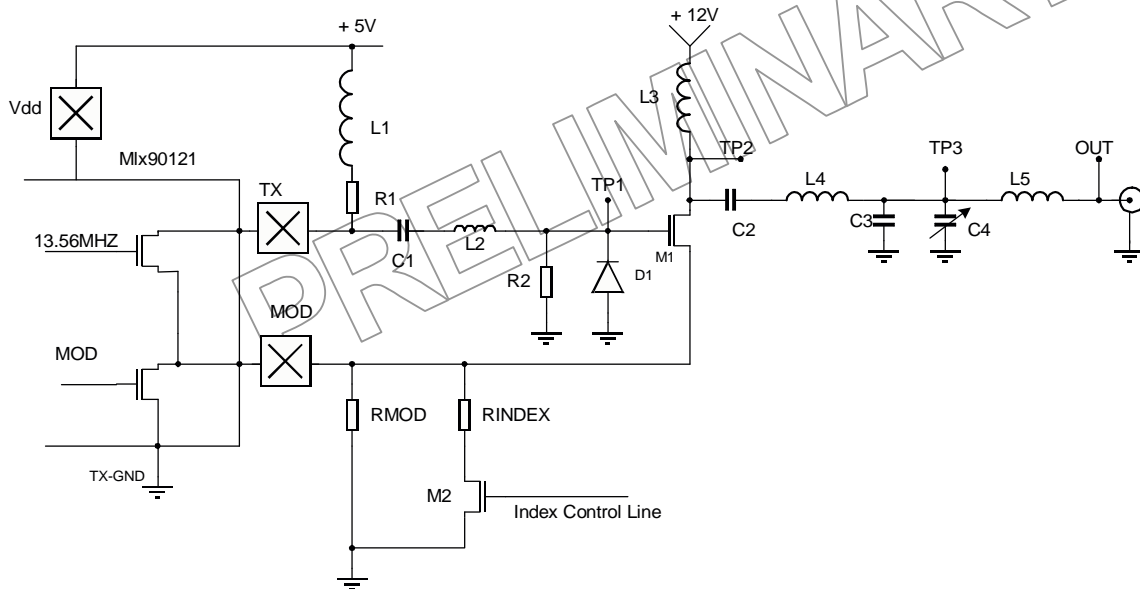

### 2.2. Recommended Components:

Reference	Value	Comments
RMOD	7.5 ohms	1% or better
RINDEX	27 ohms	1% or better
M1	BS 170 or PMBF 170	

#### Notes:

Other components values do not differ from the passive matching power boost reader schematic.

Values for RMOD and RINDEX are valid only for a 12 Volts booster stage supply. Other supply voltages will require different values for RMOD and RINDEX.

**2.3. Waveforms at the antenna connector**

**2.3.1. ISO 15693, M2 switched off:**

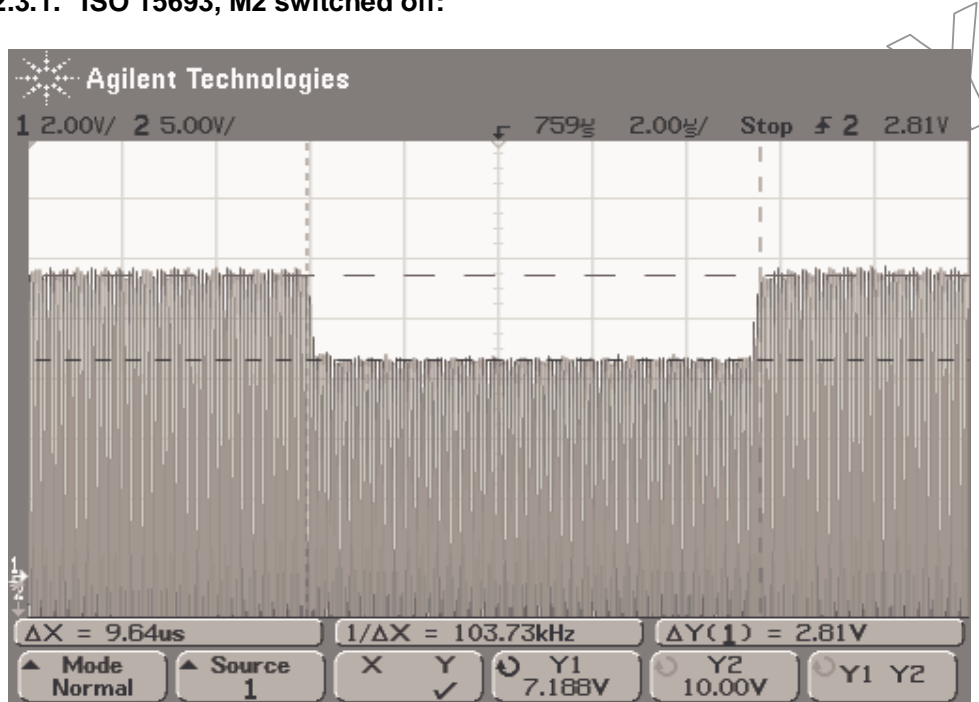

Modulation depth according to scope cursors measurements:  $m = (Y2-Y1)/(Y2+Y1) = 16.36 \%$

**2.3.2. ISO 14443, M1 switched on**

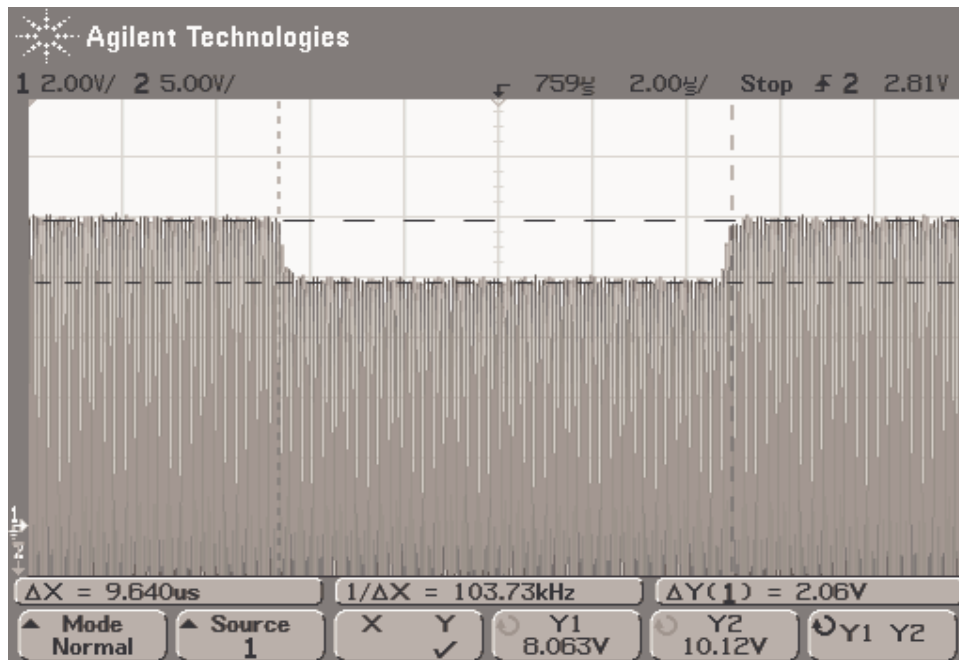

Modulation depth according to scope cursors measurements:  $m = (Y2-Y1)/(Y2+Y1) = 11.31 \%$